

Free-Choice Petri Nets without Frozen Tokens, and Bipolar Synchronization Systems

Joachim Wehler*

Ludwig-Maximilians-Universität

München Germany

joachim.wehler@gmx.net

Abstract. Bipolar synchronization systems (BP-systems) constitute a class of coloured Petri nets, well suited for modelling the control flow of discrete dynamical systems. Every BP-system has an underlying ordinary Petri net, a T-system. It further has a second ordinary net attached, a free-choice system. We prove that a BP-system is safe and live if the T-system and the free-choice system are safe and live and the free-choice system in addition has no frozen tokens. This result is the converse of a theorem of Genrich and Thiagarajan and proves an old conjecture. As a consequence we obtain two results about the existence of safe and live BP-systems with prescribed ordinary Petri nets. For the proof of these theorems we introduce the concept of a morphism between Petri nets as a means of comparing different Petri nets. We then apply the classical theory of free-choice systems.

Keywords: Bipolar synchronization system, free-choice system, frozen token, Petri net morphism, structurally free of blocking.

Introduction

Bipolar synchronization systems (BP-systems) constitute a class of coloured Petri nets, well suited for modelling the control flow of discrete distributed dynamical systems. BP-systems have been introduced in 1984 by Genrich and Thiagarajan [GT1984].

*Address for correspondence: Ludwig-Maximilians-Universität, Fakultät für Mathematik, Informatik und Statistik, Theresienstrasse 39/I, D-80333 München, Germany

BP-systems have two token colours, high-tokens and low-tokens, and they have coloured transitions with firing modes depending on the combination of high- and low-tokens at their pre-places. As a consequence a transition decides not only on enabling a subsequent activity but also about skipping it. The flow of high-tokens shows the pattern of activation, the flow of low-tokens the pattern of skipping activities. The firing modes of a given transition obey either an AND-rule or a XOR-rule.

BP-systems have seldom been studied in the context of Petri nets since 1984. Today however they are used implicitly in many commercial projects which focus on business process modelling: Because the prevalent language for business process modelling in Germany is the language of Event-driven Process Chains (EPCs), invented in 1992 by Keller, Nüttgens and Scheer (cf. [Sch1994]). EPCs model the control flow of a business process by using the logical connectors AND, XOR and OR. The semantics of EPCs can be formalized by translation into the class of Boolean Petri nets [LSW1998]. Hereby EPCs with only AND or XOR-connectors translate into BP-systems. Therefore any analysis of a BP-system clarifies the behaviour of an AND/XOR-EPC [Weh2007]. The concept of low-tokens has also been transferred separately to EPCs by different authors [GL2005], [MA2006].

Genrich and Thiagarajan observed that the flow of high-tokens of a BP-system projects onto the token flow of a corresponding free-choice system. We call it the high-system of the BP-system. Abstracting from the colours of a BP-system leads to a second ordinary Petri net. This T -system however keeps the net structure of places, transitions and directed arcs. We call it the skeleton of the BP-system. Forgetting about the colours is formalized by a canonical Petri net morphism from the BP-system to its skeleton. Due to this morphism the safeness of a BP-system follows from the safeness of its skeleton. Conversely, safeness and liveness of a BP-system imply the analogous properties of its skeleton, thanks to a lifting lemma for the morphism.

Genrich and Thiagarajan already proved that the high-system of a safe and live BP-system is safe and live itself. Moreover the high-system has no frozen tokens. Both results follow from a second lifting lemma. The new result of the present paper proves the converse of the theorem of Genrich and Thiagarajan. Our main result (Theorem 4.6):

A BP-system is safe and live iff its high-system is safe and live without frozen tokens and its skeleton is safe and live.

For the proof of Theorem 4.6 we conclude from the lifting lemma that deadlock-freeness is sufficient for the liveness of the BP-system. This result has also already been shown by Genrich and Thiagarajan. But safeness and liveness of high-system and skeleton do not suffice to exclude a deadlock of the BP-system. Therefore we intensify the concept of a deadlock to the stronger concept of a deadlocking circle. It consists of an alternating series of closing XOR- and AND-transitions. Firing the AND-transition in the high-system presupposes firing the XOR-transition, yet firing the XOR-transition in the skeleton presupposes firing the AND-transition. Therefore the transitions in the BP-system block each other. We prove that every dead BP-system has a deadlocking circle if its high-system and skeleton are safe and live. On the other hand, any deadlocking circle is excluded by the absence of frozen tokens.

The essential means for proving the latter result is a theorem about restricted free-choice nets: The high-net of a BP-system belongs to a subclass class of free-choice nets, where well-formedness is characterized by the absence of certain handles on elementary circuits. Using circuits allows us to carry a common type of reasoning from T -systems to the high-system of a BP-system. A further input for our proof is the simple observation that an activated T -component in a free-choice system without frozen tokens must already contain all tokens. This result has the structural analogy that in the underlying net T -components and P -components intersect each other.

Subsequently, we draw two conclusions from Theorem 4.6 concerning the existence of safe and live BP-systems with prescribed high-system (Theorem 5.3) or prescribed skeleton (Theorem 5.5).

The present paper uses results for free-choice systems which were not at the disposal of Genrich and Thiagarajan in 1984. They were developed afterwards by Best, Desel, Esparza and Silva.

1. Components and handles in free-choice systems

We will assume that the reader is familiar with the basic properties of Petri net theory, in particular that one knows finite *ordinary* Petri nets (N, μ) . Here the net $N = (P, T, F)$ comprises a finite set P of places, a finite set T of transitions and a set $F \subseteq (P \times T) \cup (T \times P)$ of directed arcs, while $\mu : P \rightarrow \mathbf{N}$ denotes the initial marking of the net. But often we will dispense with an explicit notation for the set of places, transitions and arcs; we use the shorthand $x \in N$ for a node $x \in P \cup T$. We shall write $pre(x) := \bullet x$ for the pre-set and $post(x) := x \bullet$ for the post-set of a node $x \in N$ and extend this notation to subsets $X \subseteq P \cup T$ by setting

$$pre(X) := \bigcup_{x \in X} pre(x) \quad \text{and} \quad post(X) := \bigcup_{x \in X} post(x).$$

For the convenience of the reader and to fix the notation we recall some concepts which are used throughout the paper. Clusters group conflicting transitions and their pre-set.

1.1. Definition (Cluster)

Consider a net $N = (P, T, F)$. The *cluster* of a node $x \in P \cup T$, denoted $cl(x)$, is the minimal set of nodes so that

- $x \in cl(x)$,
- if a place $P \in p$ belongs to $cl(x)$, then also $post(p) \subseteq cl(x)$, and
- if a transition $t \in T$ belongs to $cl(x)$, then also $pre(t) \subseteq cl(x)$.

For a subset $X \subseteq P \cup T$ we denote the union of all clusters of nodes from X by

$$cl(X) := \bigcup_{x \in X} cl(x)$$

A path (x_0, x_1, \dots, x_n) with nodes $x_i \in P \cup T$ is named *elementary*, if $x_i \neq x_j$ for all pairs $i \neq j$. A *circuit* is a path (x_0, x_1, \dots, x_n) with $x_n = x_0$, it is named *elementary circuit* if the path $(x_0, x_1, \dots, x_{n-1})$ is elementary. The *concatenation of two paths* $\alpha = (x_0, x_1, \dots, x_n)$ and $\beta = (y_0, y_1, \dots, y_m)$ with $x_n = y_0$ is the path $\alpha * \beta := (x_0, x_1, \dots, x_n, y_1, \dots, y_m)$.

The *concatenation of two occurrence sequences* σ_1 and σ_2 is denoted by $\sigma_1 \cdot \sigma_2$. A *partial subnet* of $N = (P, T, F)$ is a net $N' = (P', T', F')$ with $P' \subseteq P$, $T' \subseteq T$, $F' \subseteq F \cap [(P' \times T') \cup (T' \times P')]$. In case $F' = F \cap [(P' \times T') \cup (T' \times P')]$ the net N' is named *subnet* of N . If two nodes of a subnet are incident in the ambient net, they are also incident in the subnet. While two nodes of a partial subnet, which are incident in the ambient net, are not necessarily incident in the partial subnet.

If $X \subseteq P \cup T$ is a set of nodes of the net $N = (P, T, F)$ then the triple $(X \cap P, X \cap T, F \cap (X \times X))$ is a subnet of N , called the subnet of N generated by X . To simplify the notation we will not distinguish between an elementary path (x_0, \dots, x_n) in N and the partial subnet of N with nodes $x_i, i = 0, \dots, n$, and directed arcs $(x_i, x_{i+1}), i = 0, \dots, n - 1$. Consider a net N and two partial subnets $N_1, N_2 \subseteq N$. A *handle* on N_1 is an elementary path in N

$$\alpha = (x_0, \dots, x_n) \quad \text{with} \quad \alpha \cap N_1 = \{x_0, x_n\}.$$

In case of a transition x_0 and a place x_n the handle is called a *TP-handle*. Analogously one defines a *PT-handle*. A *bridge* from N_1 to N_2 is an elementary path in N

$$\alpha = (x_0, \dots, x_n) \quad \text{with} \quad \alpha \cap N_1 = \{x_0\} \quad \text{and} \quad \alpha \cap N_2 = \{x_n\}.$$

In case of a transition x_0 and a place x_n the bridge is called a *TP-bridge*.

A Petri net is *live* if for any transition and for any reachable marking μ an occurrence sequence σ exists, which is enabled at μ , such that firing σ creates a marking, which enables the given transition. A Petri net is *bounded* if a natural number exists, which bounds the token content of every place at every reachable marking. The Petri net is *safe* if the bound can be chosen equal to 1. A net N is *well-formed* if it has a marking μ , so that the Petri net (N, μ) is live and bounded.

Petri nets with branched places but unbranched transitions are sufficient to model processes with alternative runs, but they fail to capture concurrent process runs. A Petri net with unbranched transitions is named *P-system*, its underlying net is named *P-net*. Complementary to that, Petri nets with branched transitions but unbranched places are sufficient to model processes with concurrency, but they fail for processes with alternative runs. A Petri net with unbranched places is named *T-system*, its underlying net is named *T-net*. A *basic circuit* of a *T-system* is an elementary circuit marked with a single token.

A marking μ of a Petri net is a *home state* if any reachable marking enables an occurrence sequence, the firing of which creates μ . A Petri net (N, μ) is *cyclic* if its initial marking μ is a home state. Live and bounded *P-systems* and *T-systems* are cyclic.

Neither *P-systems* nor *T-systems* are sufficient to model real world processes. In general one has an interplay of choice and concurrency of actions. To facilitate the study of general ordinary Petri nets (N, μ) one searches for subnets of N which are *P-nets* or *T-nets*. These subnets are named *components* (cf. [DE1995], Definition 5.1 and Definition 5.11).

1.2. Definition (Components)

Consider a net N .

- i) A subnet N_P of N which is generated by a nonempty subset X of nodes, is a *P-component* of N if N_P is a strongly connected *P-net* with

$$pre(p) \cup post(p) \subseteq X \quad \text{for all places } p \in X.$$

A subnet N_T of N which is generated by a nonempty subset X of nodes, is a *T-component* of N if N_T is a strongly connected *T-net* with

$$pre(t) \cup post(t) \subseteq X \quad \text{for all transitions } t \in X.$$

- ii) A P -component of N which is marked with a single token at a marking μ of N is a *basic component* of the Petri net (N, μ) .
- iii) A marking μ of N *activates* a T -component N_T of N if the T -system (N_T, μ_T) is live, where $\mu_T := \mu|_{N_T}$ denotes the restriction of the marking μ to the places of N_T .

A P -component of N is distinguished in that its token content does not change, when firing an arbitrary transition of N . And firing all transitions of a T -component reproduces the original marking of N .

A first common generalization of P -systems and T -systems are free-choice systems. They allow the combination of alternatives and concurrency as long as a certain conflict condition is satisfied: If one transition from a set of transitions in structural conflict is enabled, then all other conflicting transitions are enabled too. From the theory of free-choice systems as presented in [DE1995]¹ we will now explicitly state some concepts and theorems fundamental for the present paper.

1.3. Definition (Free-choice system)

A net $N = (P, T, F)$ is a *free-choice net* if for every two transitions $t_1, t_2 \in T$

$$\text{either } pre(t_1) \cap pre(t_2) = \emptyset \text{ or } pre(t_1) = pre(t_2).$$

A *restricted free-choice net* is a net which satisfies the stronger condition: For every two transitions $t_1, t_2 \in T$

$$\text{either } pre(t_1) \cap pre(t_2) = \emptyset \text{ or } pre(t_1) = pre(t_2) = \{p\}$$

with a single place $p \in P$. A marked (restricted) free-choice net (N, μ) is named *(restricted) free-choice system*.

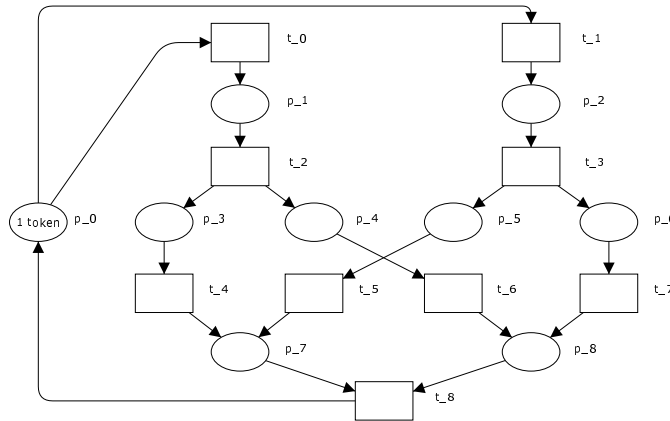

Figure 1. Live and safe restricted free-choice system

The restricted free-choice system from Fig. 1 is safe and live, therefore its underlying net is well-formed. It shows a non-trivial entangling of alternatives and concurrency. Free-choice systems and in

¹Different from [DE1995] we talk about P -components instead of S -components.

particular restricted free-choice systems are one of the two essential classes of Petri nets in the present paper. They will be used in the main part of the paper to derive properties of BP-systems, which are certain coloured Petri nets and form the second class of Petri nets considered in this paper.

Fig. 2 shows a type of conflict which is forbidden in free-choice nets: There are three transitions in structural conflict and markings are possible which enable only one of the transitions. All transitions together with their pre-places form a single cluster.

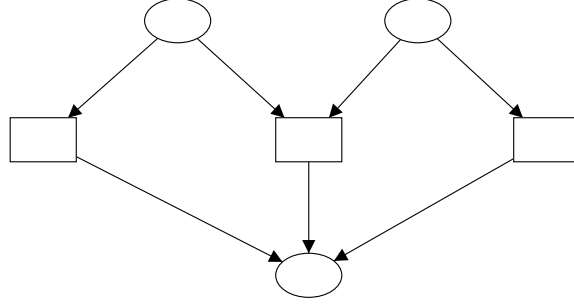

Figure 2. Type of structural conflict which is forbidden for free-choice nets

P -components and T -components are of fundamental importance for free-choice nets and we will heavily rely on them.

The free-choice net N from Fig. 1 has two P -components and two T -components.

One P -component is the subnet N_P of N generated by the set

$$\{p_0, p_1, p_2, p_3, p_5, p_7, t_0, t_1, t_2, t_3, t_4, t_5, t_8\}.$$

One T -component is the subnet N_T of N generated by the set

$$\{t_0, t_2, t_4, t_6, t_8, p_0, p_1, p_3, p_4, p_7, p_8\}.$$

Both P -components are basic components of (N, μ) and both T -components are activated at μ .

For the convenience of the reader we reproduce the simple proof of the following Lemma 1.4.

1.4. Lemma (Intersection of components)

The intersection of a P -component N_P with a T -component N_T of a net is a set of disjoint elementary circuits. Possibly the set is empty.

Proof:

Consider a place $p \in N_{PT} := N_P \cap N_T$. Because $p \in N_T$ the place has only a single pre-transition and only a single post-transition in N_T . Because N_P is a P -component, all pre-transitions and all post-transitions of $p \in N_T$ belong to N_P . Therefore $p \in N_{PT}$ has a unique pre-transition $t_{pre} \in pre(p) \cap N_{PT}$ as well as a unique post-transition $t_{post} \in post(p) \cap N_{PT}$. Analogously a transition $t \in N_{PT}$ has a unique pre-place $p_{pre} \in pre(t) \cap N_{PT}$ and a unique post-place $p_{post} \in post(t) \cap N_{PT}$. Therefore N_{PT} is the disjoint union of elementary circuits. \square

A key term of the present paper is the concept of frozen tokens: A token in a Petri net is frozen at a given place iff there is an enabled infinite occurrence sequence, which does not move the token. The following Definition 1.5, i) is equivalent to ([BD1990], Def. 6.1). Here we employ for two markings ν, μ of a net $N = (P, T, F)$ the following notation: $\nu < \mu$ iff $\nu(p) \leq \mu(p)$ for all places $p \in P$ and $\nu(p_0) < \mu(p_0)$ for at least one place $p_0 \in P$.

1.5. Definition (Frozen tokens, structurally free of blocking)

- i) A Petri net (N, μ_0) has no *frozen tokens* iff for every reachable marking μ the following holds: For every marking $\nu < \mu$ the Petri net (N, ν) has no enabled infinite occurrence sequence.
- ii) A net is *structurally free of blocking* iff every P -component intersects every T -component in a non-empty set.

For a live free-choice system the absence of frozen tokens is equivalent to the structural property from Definition 1.5, cf. [BD1990], Theor. 6.2.

1.6. Lemma (Frozen tokens, structurally free of blocking)

A live free-choice system has no frozen tokens iff it is safe and the underlying net is structurally free of blocking.

The net underlying the free-choice system from Fig. 1 is structurally free of blocking, as all its components contain the place p_0 .

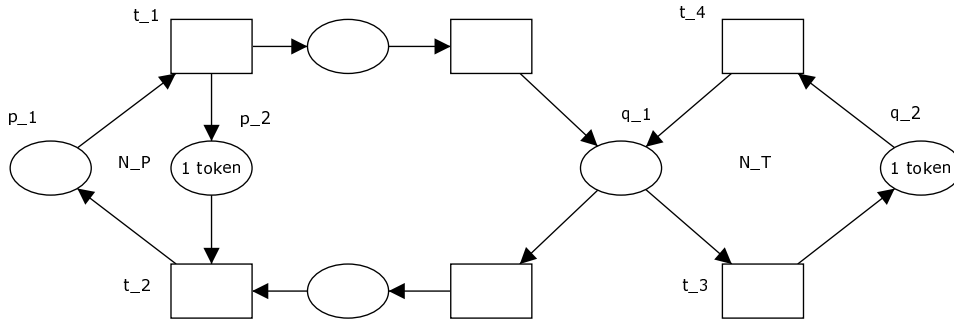

Figure 3. Free-choice system with a frozen token

The net underlying the free-choice system from Fig. 3 is not structurally free of blocking. Its P -component N_P with nodes $\{p_1, t_1, p_2, t_2\}$ is disjoint from the T -component N_T with nodes $\{q_1, t_3, q_2, t_4\}$. The two free-choice systems from Fig. 1 and Fig. 3 are live and safe. The first one has no frozen tokens. In contrast the system from Fig. 3 has a frozen token at the place p_2 : The marking from Fig. 3 activates the T -component N_T and therefore also an infinite occurrence sequence, which does not move the token at p_2 . The system from Fig. 3 will be studied later in a broader context.

Any strongly connected T -net is structurally free of blocking. In particular, a safe and live T -system has no frozen tokens. Even a much stronger result holds: Every enabled infinite occurrence sequence of

a strongly connected T -system fires each transition of the net an infinite number of times (cf. [DE1995], Proof of Theor. 3.17).

For the class of restricted free-choice nets - but not for free-choice nets in general - there exists a characterization of well-formedness in terms of handles and bridges. This characterization in Theorem 1.7 is one of the main ingredients for the proof of Theorem 4.6. The result is due to Esparza and Silva, after preparatory work of Desel (cf. [ES1990], Theor. 4.2).

1.7. Theorem (Well-formedness of restricted free-choice nets)

A restricted free-choice net is well-formed iff it is strongly connected, no elementary circuit has a TP -handle and every PT -handle on an elementary circuit has a TP -bridge from the handle to the circuit.

With the help of Theorem 1.7 one easily confirms that the underlying net of the restricted free-choice net from Fig. 1 is well-formed. For a restricted free-choice net which is not well-formed we refer to Fig. 4: Each of its four elementary circuits has a TP -handle. The free-choice net will be studied in the context of BP-systems in Chapter 2.

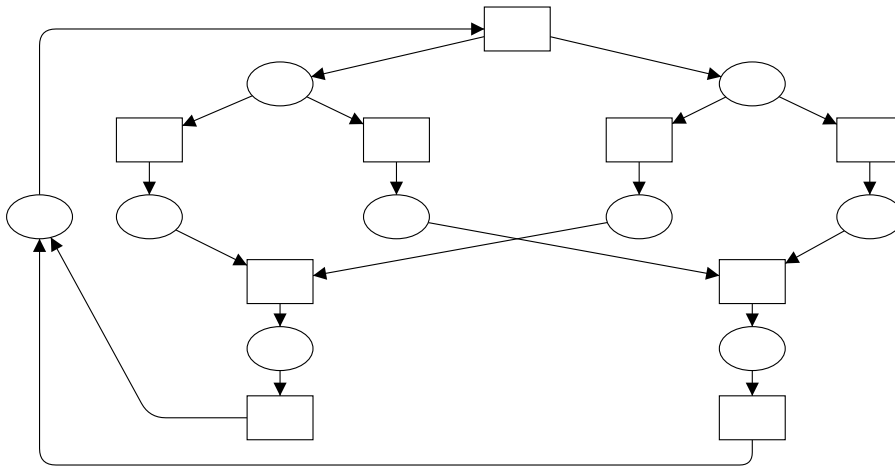

Figure 4. Restricted free-choice net, which is not well-formed

As a corollary to Theorem 1.7 the following Proposition 1.8 states the main result about the intersection of components in a well-formed restricted free-choice net which is structurally free of blocking.

1.8. Proposition (Intersection of components)

Consider a well-formed restricted free-choice which is structurally free of blocking.

- i) Each pair (N_P, N_T) with a P -component N_P and a T -component N_T intersects in a single elementary circuit $\gamma = N_P \cap N_T$.
- ii) Each elementary circuit γ is the intersection $\gamma = N_P \cap N_T$ of a P -component N_P with a T -component N_T .

Proof:

According to Lemma 1.4 the intersection $N_P \cap N_T$ is either empty or a set of disjoint elementary circuits.

ad i) In case of N being structurally free of blocking the intersection $N_{PT} := N_P \cap N_T$ is non-empty. Assume that N_{PT} contains two disjoint circuits $\gamma_1 \neq \gamma_2$. Within N_T there exists a bridge α_{12} from γ_1 to γ_2 . It starts with a transition, because places of a T -component do not branch. Analogously within N_P there exists a bridge α_{21} from γ_2 to γ_1 , which ends with a place. Let γ be the segment of γ_2 from the end of α_{12} to the start of α_{21} . The concatenation $\alpha_{12} * \gamma * \alpha_{21}$ induces a TP -handle on γ_1 . It contradicts the well-formedness of the restricted free-choice net according to Theorem 1.7 which finishes the proof.

ad ii) Any elementary circuit γ of a well-formed free-choice net is contained in the intersection of a P -component N_P with a T -component N_T . This result is due to Thiagarajan and Voss (cf. [TV1984], Chap. 5). According to part i) the intersection $N_P \cap N_T$ is a single elementary circuit. Therefore $\gamma = N_P \cap N_T$. \square

Fig. 1 illustrates Proposition 1.8: The free-choice net has four elementary circuits. Each of them is the intersection of a P -component and a T -component. There are two P -components and two T -components.

1.9. Corollary (An activated T-component implies liveness)

Consider a free-choice net N which is well-formed and structurally free of blocking and a T -component N_T of N . If a marking μ of N activates N_T , then (N, μ) is live.

Proof:

As a consequence of Commoners Theorem a free-choice system (N, μ) with well-formed free-choice net N is live iff it is covered by a set of marked P -components (cf. [DE1995], Theor. 5.8). Any P -component N_P of N intersects N_T in an elementary circuit according to Proposition 1.8. Liveness of $(N_T, \mu|_{N_T})$ implies that each of these elementary circuits is marked. Therefore N_P is marked. \square

Another important application of Theorem 1.7 is Proposition 1.10.

1.10. Proposition (Obstruction against being well-formed and structurally free of blocking)

Consider a restricted free-choice net N . Assume a T -component N_T , a P -component N_P and a path $\alpha = (x_T, x_1, \dots, x_n, x_P)$ from a node $x_T \in N_T - N_P$ to a node $x_P \in N_P - N_T$, such that

$$\alpha' \cap N_T \cap N_P = \emptyset$$

with $\alpha' := (x_1, \dots, x_n)$ the path resulting from α by excluding the endpoints. Then N cannot be well-formed and structurally free of blocking.

Proof:

We argue by means of an indirect proof and assume that N is well-formed and structurally free of blocking. The intersection $\gamma := N_T \cap N_P$ is an elementary circuit according to Proposition 1.8. Within N_T there exists a bridge α_T from γ to x_T and within N_P a bridge α_P from x_P to γ . The bridge α_T starts with

a transition, because branched nodes of N_T are transitions, and α_P ends with a place, because branched nodes of N_P are places. The concatenation $\alpha_T * \alpha * \alpha_P$ is a TP -handle on γ , possibly after shortening it to an elementary path, keeping fixed its start and end. According to Theorem 1.7 this fact contradicts N being well-formed. \square

The following Proposition 1.11 is the main result about T -components in live and bounded free-choice systems. We will apply it to live and safe free-choice systems without frozen tokens. Here it serves to collect all tokens of a reachable marking within a given T -component.

1.11. Proposition (Activation of T-components)

Every T -component N_T of a live and bounded free-choice system can be activated by a reachable marking. In particular, an enabled occurrence sequence σ without any transition from $cl(N_T)$ exists, so that the firing of σ creates a marking, which activates N_T .

Proof:

[DE1995], Theor. 5.20 shows the existence of an enabled occurrence sequence σ without transitions from N_T , such that firing σ creates a marking, which activates N_T . But their proof also demonstrates the stronger version of Proposition 1.11 which excludes from σ even transitions from $cl(N_T)$. \square

A marking which enables only transitions from a single cluster is a blocking marking.

1.12. Definition (Blocking marking)

A *blocking marking* associated to a cluster from a free-choice system is a reachable marking which enables every transition from the cluster but no other transition of the system.

1.13. Lemma (Blocking markings in the absence of frozen tokens)

Any cluster of a safe and live restricted free-choice system without frozen tokens has a blocking marking, which can be reached without firing any transition from the cluster. The blocking marking is uniquely determined and is a home state.

Proof:

Denote by c the given cluster.

- i) Existence of blocking markings: Let $FCS = (N, \mu)$ be the given free-choice system. Because FCS has no frozen tokens, for any cluster of N and at every reachable marking an enabled occurrence sequence exists, the firing of which creates a blocking marking of the given cluster. Obviously one can assume that the occurrence sequence does not contain any transition from the cluster.
- ii) Every T -component with one place of c is activated at a blocking marking μ_{block} of c and contains all tokens of μ_{block} : Otherwise N_T could be activated according to Proposition 1.11 by firing a non-empty enabled occurrence sequence with no transition from $cl(N_T)$. But such occurrence

sequences do not exist, because μ_{block} is a blocking marking and the only transitions activated at μ_{block} belong to $c \subset cl(N_T)$.

Because N_T is activated at μ_{block} , there exists an infinite occurrence sequence of the T -system $(N_T, \mu_{block}|N_T)$ and a posteriori of (N, μ_{block}) . The fact that FCS has no frozen tokens, implies that all tokens of μ_{block} mark places of N_T .

- iii) Uniqueness of blocking markings: We consider two blocking markings $\mu_{1,block}$ and $\mu_{2,block}$ associated to the cluster c . They can be considered as markings of a suitable T -component N_T according to part ii). We prove that $\mu_{2,block}$ is reachable in $(N_T, \mu_{1,block})$. Due to the Reachability Theorem for live T -systems ([DE1995], Theor. 3.21) we have to prove that $\mu_{1,block}$ and $\mu_{2,block}$ agree on every elementary circuit γ of N_T , i.e. $\mu_{1,block}(\gamma) = \mu_{2,block}(\gamma)$. Due to Proposition 1.8 there exists a P -component N_P with $\gamma = N_P \cap N_T$. The equality $\mu_{1,block}(N_P) = \mu_{2,block}(N_P)$ and part ii) imply $\mu_{1,block}(N_P \cap N_T) = \mu_{2,block}(N_P \cap N_T)$. Blocking markings of the safe and live T -system $(N_T, \mu_{1,block})$ are unique ([GT1984], Theor. 1.15), which implies $\mu_{1,block} = \mu_{2,block}$.
- iv) The uniqueness of blocking markings and part i) imply that any blocking marking is a home state. \square

Lemma 1.13 has a far reaching generalization. The reachability of unique blocking markings in a bounded and live free-choice system is a deep theorem of Gaujal, Haar and Mairesse ([GHM2003], Theor. 3.1). The proof is much more difficult than our proof of Lemma 1.13. Their theorem shows, that the two concepts "blocking marking" and "structurally free of blocking" are independent: Bounded and live free-choice systems have unique blocking markings independently from the underlying net being structurally free of blocking or not. Therefore one should not confuse the two different concepts "blocking marking" and "structurally free of blocking", the common use of the word "blocking" is misleading.

A marking μ with the properties from Definition 1.12 is named "blocking marking", because it blocks every transition, which does not belong to the given cluster. Those transitions are not enabled at μ .

Being "structurally free of blocking" is a structural property of the net, it does not refer to a distinguished marking. The name can be explained by Lemma 1.6: At any live and safe marking of the net it is impossible to mark a pre-place of a transition with a token and to fire afterwards an infinite occurrence sequence, which does not move the token: It is not possible to block a transition with a token with respect to an infinite occurrence sequence.

2. BP-Systems and their derived ordinary Petri nets

A BP-system is a coloured Petri net. It collects the two truth values "true, false" into a global set BOOLE of token colours, while the firing modes of its transitions represent the Boolean logic of AND and XOR. A token with the colour "high (= true)" is called a high-token and a token with the colour "low (= false)" is called a low-token. Fig. 5 shows an example of a BP-system. It is marked with one high-token.

BP-systems are coloured Petri nets (cf. [Jen1992]) but for the present paper we do not need the latter concept in full generality.

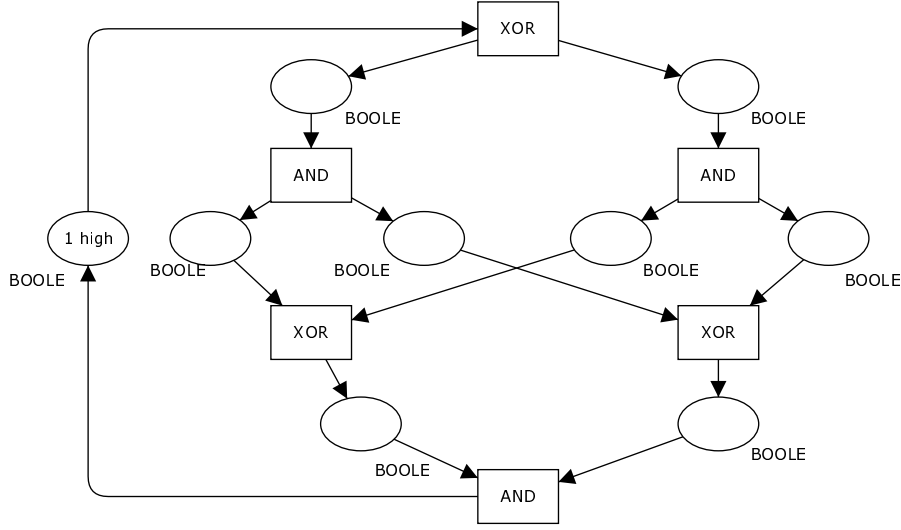

Figure 5. BP-system

2.1. Definition (BP-system)

i) A bipolar synchronization graph (BP-graph) BGP is a coloured net. It extends a T -net $N = (P, T, F)$ by attaching to each place $p \in P$ the fixed set

$$C(p) = BOOLE := \{high, low\}$$

with two token colours and provides each transition $t \in T$ with one from two types of logic:

- An AND-transition $t = t_{AND}$ has a set of firing modes $B(t) = \{high, low\}$ with two elements: The high-mode (respectively low-mode) is enabled iff all pre-places of t_{AND} are marked with at least one high-token (respectively low-token). Its firing consumes one high-token (respectively low-token) from each pre-place and creates one high-token (respectively low-token) on every post-place.
- An XOR-transition $t = t_{XOR}$ with n pre-places and m post-places has a set of firing modes $B(t)$ with $n \cdot m$ high-modes $b_{(i,j)}$ and one low-mode: The high-mode with index (i, j) , $1 \leq i \leq n$, $1 \leq j \leq m$, is enabled iff the i -th pre-place is marked with at least one high-token and all other pre-places with at least one low-token. Firing the high-mode consumes a high-token from the i -th pre-place and a low-token from every other pre-place and creates a high-token at the j -th post-place and a low-token at every other post-place. The low-mode is enabled iff all pre-places are marked with at least one low-token. Firing the low-mode consumes a low-token from each pre-place and creates a low-token at every post-place.

Adhering to the common notation of coloured nets we call a pair (p, c) with $p \in P, c \in C(p)$, a *token element* and a pair (t, b) with $t \in T, b \in B(t)$, a *binding element*. A binding element is named *low binding element*, if its firing consumes and creates only low-tokens. Otherwise it is named *high binding element*.

element. A transition with a single pre-place and two or more post-places is an *opening transition*, a transition with a single post-place and two or more pre-places is called a *closing transition*. Opening transitions with exactly two post-places and closing transitions with exactly two pre-places are called *binary transitions*. The BP-graph is called *binary* if all its transitions are binary.

ii) A *bipolar synchronization system* (BP-system) is a coloured Petri net $BPS = (BPG, \mu)$ with a BP-graph BPG and an initial marking μ with at least one high-token.

The binary BP-graph underlying the BP-system from Fig. 5 contains one opening XOR-transition and two closing XOR-transitions. There are no XOR-pairs, formed by an opening and a closing XOR-transition. Similarly there are no AND-pairs. Instead AND-transitions and XOR-transitions are crosslinked.

The present paper deals with questions of liveness of high binding elements. All BP-systems we are dealing with in the final theorems will be strongly connected, therefore each transition will have at least one pre-place and at least one post-place. If the initial marking of a strongly connected BP-graph had no high-tokens, one could enable at most the low-modes of its transitions. Their firing creates again low-tokens only. Therefore we excluded initial markings without any high tokens in Definition 2.1, part ii). Actually there is no need to consider markings without high-tokens. Such a Petri net would model a system, where each activity is skipped. This can be achieved already with the simpler model of the corresponding T -system.

As is well known, the semantics of coloured Petri nets can be given in terms of P/T -systems. In particular, every BP-graph BPG expands into an ordinary net BPG^{flat} : Places and transitions of BPG^{flat} are by definition the token elements and binding elements of BPG . Any token from a marking of BPG induces a token at that place of BPG^{flat} , which corresponds to the token colour. Therefore any marking μ of BPG induces a marking μ^{flat} of BPG^{flat} and the occurrence sequences of the BP-system $BPS = (BPG, \mu)$ and the ordinary Petri net

$$BPS^{flat} := (BPG^{flat}, \mu^{flat})$$

its *flattening*, correspond bijectively. The flattening of the binary closing AND- and XOR-transitions of BPG are the ordinary nets from Fig. 6. An analogous flattening is obtained for the opening transitions just by reversing the arcs.

The white components of the ordinary nets in Fig. 6 form part of an ordinary Petri net

$$BPS^{low} = (BPG^{low}, \mu^{low}),$$

which is called the *low-system* of BPS . The net BPG^{low} is the subnet of BPG^{flat} generated by all low-places and all low-transitions.

Factoring out the low-system from the flattening leaves as quotient the ordinary net

$$BPS^{high} = (BPG^{high}, \mu^{high}),$$

the *high-system* of BPS . The net BPS^{high} is generated by the shaded components from Fig. 6, i.e. by all high-places and high-transitions of BPG^{flat} . It is a restricted free-choice system.

If one forgets about all colours of BPS , i.e. about the difference between token colours and about the difference between firing modes, one obtains a further ordinary Petri net, the *skeleton*

$$BPS^{skel} = (BPG^{skel}, \mu^{skel})$$



Figure 6. Flattening of closing transitions of different logical type (1 = high, 0 = low)

of BPS . The skeleton is a T -system. Accordingly, BP-systems generalize T -systems. They add the possibility of choice and represent the omission of actions by a second type of tokens.

We illustrate the different ordinary Petri nets attached to a BP-system by a series of figures. Fig. 7 (left hand side) shows a simple BP-system BPS , which represents an XOR-alternative. The figure shows the state after deciding for the left alternative. The two tokens indicate by their different colour, which alternative has been chosen. Fig. 7 (right hand side) is the corresponding skeleton BPS^{skel} , a T -system. The branching does not indicate, if it results from XOR-transitions or from AND-transitions. And the marking of BPS^{skel} does not indicate, which of the two alternatives has been chosen in BPS .

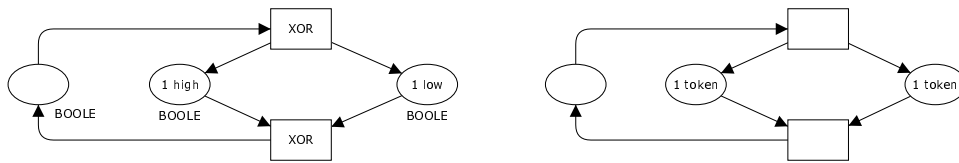

Figure 7. BP-system BPS (left) and its skeleton BPS^{skel} (right)

The flattening BPS^{flat} from Fig. 8 is an ordinary Petri net. It contains the same information as the coloured Petri net BPS , but the representation is less compact.

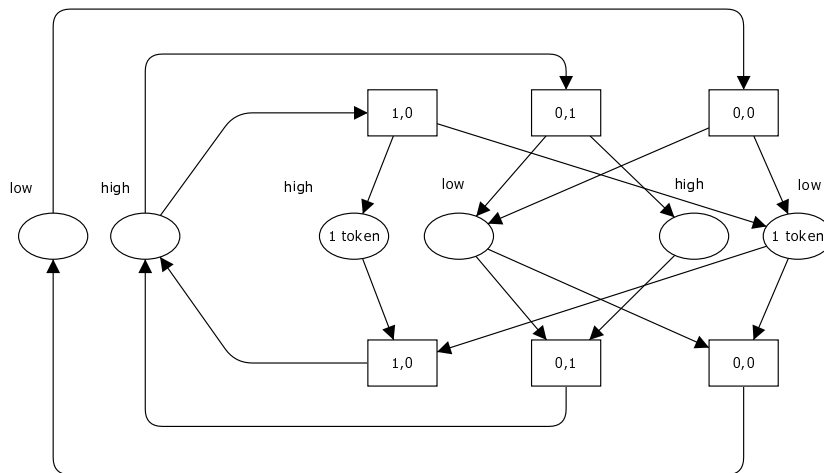

Figure 8. Flattening BPS^{flat} of the BP-system from Fig. 7 (left)

Eventually Fig. 9 (left hand side) shows the low-system BPS^{low} and Fig. 9 (right hand side) the high-system BPS^{high} . The low-system is a T -system, which is not live. The high-system is a live and safe P -system. Alike to BPS it represents the alternatives and indicates, which of the two alternatives has been chosen.

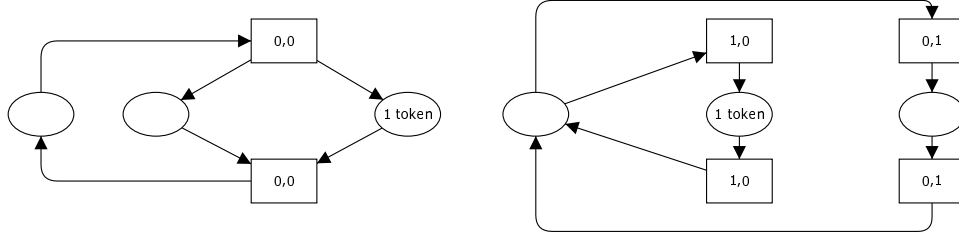

Figure 9. Low-system BPS^{low} (left) and high-system BPS^{high} (right) of the BP-system from Fig. 7

The definition of safeness translates literally from ordinary Petri nets to BP-systems: A BP-system is *safe* if the token content of any place at any reachable marking does not exceed the bound 1. We now extend the concept of liveness and deadness to BP-systems.

2.2. Definition (Live, dead, synchronization-deadlock)

Consider a BP-graph BPG , a marking μ of BPG and the BP-system $BPS := (BPG, \mu)$.

- i) A binding element of BPG is *live at μ* iff for every reachable marking μ_1 the BP-system (BPG, μ_1) has a reachable marking which enables the given binding element. BPS is *live with respect to all its high bindings* iff every high binding element of BPG is live at μ .
- ii) A transition of BPG is *high-live at μ* iff it has a high-mode which is live at μ . BPS is *high-live* iff each transition is high-live at μ .
- iii) The BP-graph BPG is *well-formed* iff a marking μ_1 exists, such that the BP-system (BPG, μ_1) is safe and high-live.
- iv) A transition of BPG is *dead at μ* iff no reachable marking of BPS enables any firing mode of the given transition. The marking μ is *dead* iff all transitions of BPG are dead at μ . BPS is *dead* iff the initial marking μ is dead.
- v) If BPS is safe, then a transition $t \in BPG$ is in a *synchronization-deadlock at μ* iff
 - either t is an AND-transition with at least one pre-place high-marked at μ and one pre-place low-marked at μ
 - or t is a XOR-transition with at least two pre-places high-marked at μ .

BPS is *free of synchronization-deadlocks* iff no transition of BPG is in a synchronization-deadlock at a reachable marking.

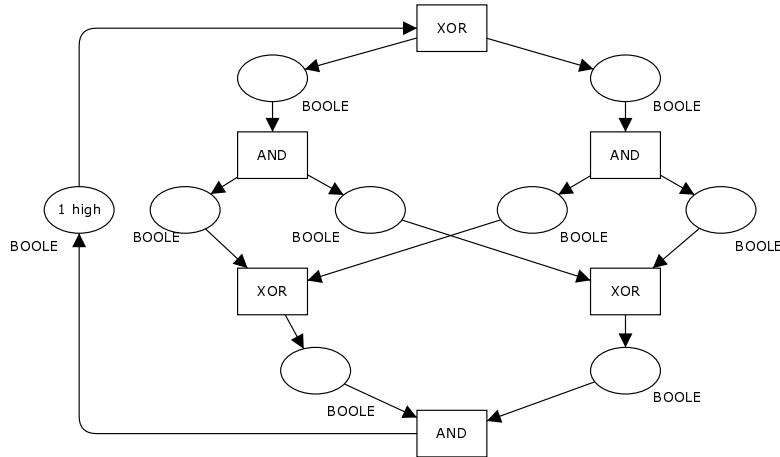

Figure 10. Safe and high-live BP-system BPS_1

In order to illustrate, how high-liveness of a BP-system may depend on certain properties of its high-system, we present three examples of safe BP-systems. The BP-system BPS_1 from Fig. 10 is safe and high-live, its high-system BPS_1^{high} in Fig. 11 is live and safe without frozen tokens.

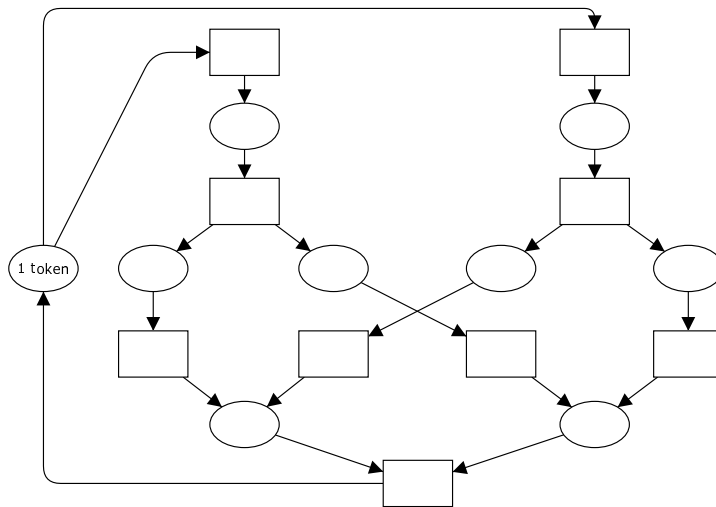
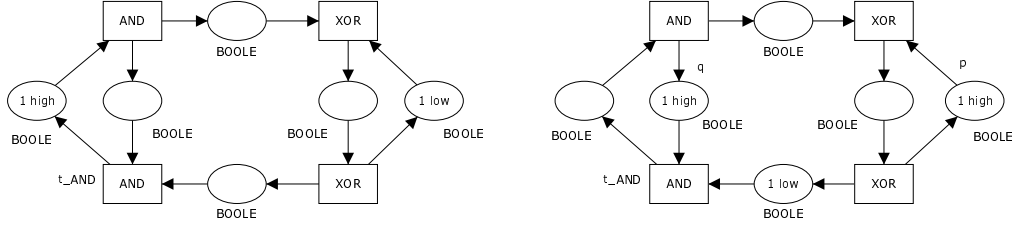
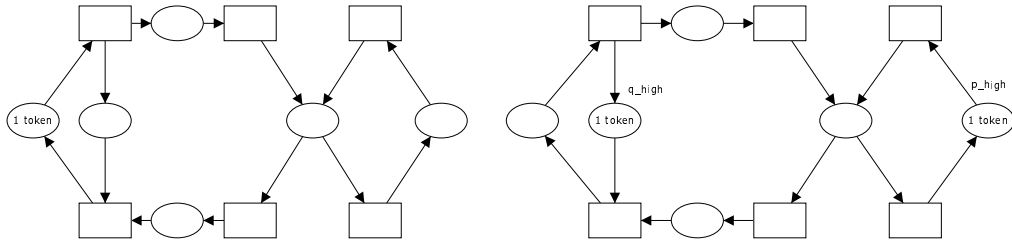

Figure 11. Safe and live high-system BPS_1^{high}

The second example is the BP-system BPS_2 obtained from BPS_1 by interchanging AND-transitions and XOR-transitions while keeping all arc-directions. Fig. 12 on the left shows BPS_2 . On the right of Fig. 12, there is a reachable marking $\mu_{2,dead}$ of BPS_2 with the two closing AND-transitions in a synchronization-deadlock.

Both BP-systems BPS_1 and BPS_2 have same the skeleton, which is a safe and live T-system. But their high-systems are different. Fig. 13 shows the dead marking $\mu_{2,dead}^{high}$ of the high-system BPS_2^{high} .

Figure 14. BP-system BPS_3 (left) with a reachable synchronization-deadlock $\mu_{3,dead}$ (right)Figure 15. High-system BPS_3^{high} (left) and marking μ_3^{high} with a frozen token at place q^{high} (right)

3. Lifting along Petri net morphisms

Between a BP-system $BPS = (BGP, \mu)$ and its derived ordinary Petri nets canonical morphisms exist:

1. The morphism $BPS^{flat} \xrightarrow{col} BPS$ maps places and transitions of the flattening BPS^{flat} onto their defining token and binding elements of BPS . The inverse image of a place of BPG has two token elements, while the inverse image of a transition of BGP consists of its different binding elements. With the help of this morphism we identify the coloured Petri net BPS and the ordinary Petri net BPS^{flat} with respect to their behaviour, in particular with respect to all their markings and occurrence sequences.
2. The morphism $BPS \xrightarrow{skel} BPS^{skel}$ projects token and binding elements of BPS onto their respective place and transition:

$$skel((p, c)) := p, skel((t, b)) := t$$

for a token element (p, c) with $c \in C(p)$ and a binding element (t, b) with $b \in B(t)$. The morphism forgets about all colours of BPS but keeps places, transitions and directed arcs.

3. The morphism $BPS^{low} \xrightarrow{low} BPS^{flat}$ embeds the low-system into the flattening as a subnet.
4. The morphism $BPS^{flat} \xrightarrow{high} BPS^{high}$ projects the flattening onto the high-system. It removes all low token elements and all low binding elements.

In the present paper we have introduced morphisms between a BP-system and its derived ordinary Petri nets in an informal way. In particular, the notation $BPS^{flat} \xrightarrow{high} BPS^{high}$ is a shorthand for a morphism

$BPS^{flat} \xrightarrow{high} PN$ onto a coloured Petri net PN with the same places, transitions and arcs as BPS^{flat} , but the zero-module of token and binding elements for all places and transitions of the low-net. For more insight into our definition of morphisms between Petri nets we refer the reader to [Weh2006].

For a node x from BGP we will often use x^{high} as a shorthand for $high(x)$ and x^{skel} as a shorthand for $skel(x)$. For a path γ in BPG from a node x_1 to a node x_2 we define an induced path γ^{high} in BPG^{high} : In BPG^{high} we first choose start and end $x_i^{high} \in high(col^{-1}(x_i))$, $i = 1, 2$. Then a unique path γ^{high} exists from x_1^{high} to x_2^{high} with $col(high^{-1}(\gamma^{high})) = \gamma$. Prescribing x_i^{high} is necessary if the node x_i is an XOR-transition, but often these nodes are implicitly determined by the context.

A morphism between two Petri nets serves to compare both objects and to derive properties of one Petri net from corresponding properties of the other. These morphisms are already implicit in the paper of Genrich-Thiagarajan [GT1984], where they are quite often used as a guideline for the reasoning. For the present paper we have decided to isolate these morphisms and to state explicitly some of their properties in separate propositions which serve as a prerequisite for proving the theorems from Chap. 4 and 5. For the convenience of the reader and striving for being self-contained we have therefore decided to reshape some proofs from [GT1984] into the new context of morphisms.

The first application of the concept of a morphism in Lemma 3.1 is quite simple.

3.1. Lemma (Deriving safeness)

A BP-system is safe if its skeleton is safe.

Proof:

Because the morphism $BPS \xrightarrow{skel} BPS^{skel}$ maps enabled occurrence sequences, it maps any reachable marking of BPS to a reachable marking of BPS^{skel} . If no reachable marking of BPS^{skel} marks a place with more than a single token, the same holds true for BPS . \square

The lifting problem considers the converse situation: Under which assumptions does a Petri net morphism $PN_1 \xrightarrow{f} PN_2$ have the *lifting property*, i.e. given an enabled occurrence sequence σ_2 of PN_2 , when does exist an enabled occurrence sequence σ_1 of PN_1 with $f(\sigma_1) = \sigma_2$? If σ_1 exists, it is named *a lift of σ_2 against f* . For the skeleton we will solve the lifting problem with Lemma 3.2, for the high-system with Corollary 3.4.

3.2. Lemma (Lifting property of the skeleton)

For a BP-system $BPS = (BPG, \mu)$ free of synchronization-deadlocks the skeleton morphism $BPS \xrightarrow{skel} BPS^{skel}$ has the lifting property. In addition, the lift to high binding elements can be prescribed along an arbitrary path: Consider an enabled occurrence sequence σ^{skel} from BPS^{skel} containing a sequence $t_0 \cdot \dots \cdot t_{n-1}$ of transitions which extends to a path in BPS

$$\gamma = (p_0, t_0, p_1, \dots, t_{n-1}, p_n) \text{ with places } p_i, \quad 0 \leq i \leq n,$$

and assume that the first place p_0 is high-marked at μ . Then σ^{skel} has a lift σ to BPS containing a sequence $(t_0, b_0) \cdot \dots \cdot (t_{n-1}, b_{n-1})$ of high binding elements (t_i, b_i) , $0 \leq i < n$.

Proof:

We may assume that σ^{skel} is a single transition $t^{skel} \in BPG^{skel}$ firing according to $skel(\mu) \xrightarrow{\sigma^{skel}} \mu_1^{skel}$. All pre-places of the corresponding transition $t \in BPG$ are marked. Because BPS is free of synchronization-deadlocks, the marking μ enables a firing mode $b \in B(t)$ of BPS with $\sigma^{skel} = skel(t, b)$. In case of an XOR-transition t the firing mode can be chosen according to the demand of γ . Therefore the occurrence sequence $\sigma := (t, b)$ of BPS is a suitable lift of σ^{skel} . \square

For a bounded and strongly connected free-choice system non-deadness implies liveness. As a first consequence from the lifting property of the skeleton we derive a similar property also for BP-systems.

3.3. Proposition (Liveness versus synchronization-deadlock)

For a strongly connected BP-system BPS with safe skeleton BPS^{skel} the following properties are equivalent:

1. BPS is high-live.
2. No reachable marking of BPS is dead.
3. BPS is free of synchronization-deadlocks and the skeleton is live.

Proof:

1 \Rightarrow 2 The proof is obvious, as liveness always implies non-deadness.

2 \Rightarrow 3 The assumption implies that at any reachable marking μ of BPS enables at least one binding element of BPG . Therefore BPS has an occurrence sequence σ of infinite length enabled at μ . It projects along $BPS \xrightarrow{skel} BPS^{skel}$ to an occurrence sequence σ^{skel} with infinite length, which is enabled at μ^{skel} . Because the skeleton BPS^{skel} is a strongly connected T -system, σ^{skel} fires each transition of BPS^{skel} . Therefore μ^{skel} marks each circuit of the skeleton and BPS^{skel} is live.

According to Lemma 3.1 BPS is safe. Because also σ fires each transition of BPS , no transition can be in a synchronization-deadlock at μ .

3 \Rightarrow 1 Consider a reachable marking μ of BPS and a given transition t of the underlying net. Because the initial marking of BPS contains at least one high-token, the same holds true for μ . Therefore a transition t_1 exists with a pre-place high-marked at μ . According to Lemma 1.13 a minimal occurrence sequence $skel(\mu) \xrightarrow{\sigma_1^{skel}} \mu_1^{skel}$ of BPS^{skel} exists with μ_1^{skel} a blocking-marking associated to the cluster of $skel(t_1)$. By Lemma 3.2 the occurrence sequence σ_1^{skel} lifts to $\mu \xrightarrow{\sigma_1} \mu_1$, so that also μ_1 enables a high-mode of t_1 . Because μ_1^{skel} is a blocking marking, the live T -system $(BPG^{skel}, \mu_1^{skel})$ contains an unmarked path β^{skel} from $skel(t_1)$ to $skel(t)$. A minimal occurrence sequence

$$\mu_1^{skel} \xrightarrow{\sigma_2^{skel}} \mu_2^{skel}$$

exists with μ_2^{skel} enabling $skel(t)$ and with the transitions from β^{skel} as a subsequence of σ_2^{skel} .

By Lemma 3.2 the occurrence sequence σ_2^{skel} has a lift $\mu_1 \xrightarrow{\sigma_2} \mu_2$, so that μ_2 enables a high-mode of t . \square

The essential step "3 \Rightarrow 1" in the proof of Proposition 3.3 as well as Corollary 3.4 have already been demonstrated by Genrich and Thiagarajan, ([GT1984], Theor. 2.12, Lemma 3.10).

3.4. Corollary (Lifting property of the high-system)

If a BP-System BPS is free of synchronization-deadlocks and has a safe and live skeleton, then the morphism $BPS^{flat} \xrightarrow{high} BPS^{high}$ has the lifting property.

Proof:

Set $BPS = (BPG, \mu)$. In $BPS^{high} = (BPG^{high}, \mu^{high})$ we consider an occurrence sequence σ^{high} firing according to $\mu^{high} \xrightarrow{\sigma^{high}} \mu_1^{high}$. Without loss of generality σ^{high} is a single transition, i.e. $\sigma^{high} = high(\sigma_h)$ with $\sigma_h := (t, b) \in BPG^{flat}$ with a transition $t \in BPG$ and a high-mode $b \in B(t)$. For the proof we shall concatenate σ_h with a second occurrence sequence σ_l of BPS^{flat} , so that $\sigma := \sigma_l \cdot \sigma_h$ is enabled in BPS^{flat} and still satisfies $\sigma^{high} = high(\sigma)$. Therefore we have to find σ_l as a suitable occurrence sequence of the low-system $BPS^{low} \subset BPS^{flat}$. In case σ_h is enabled at μ^{flat} we can choose σ_l as the empty sequence.

Otherwise $high(\sigma_h)$ is enabled at μ^{high} , but σ_h lacks enabledness at μ^{flat} . Then $\sigma_h = (t_{XOR}, b)$ with a closing XOR-transition $t_{XOR} \in BPG$ and a high-mode $b \in B(t_{XOR})$. At μ one pre-place $p \in pre(t_{XOR})$ is high-marked. Lemma 3.1 implies that BPS is safe, therefore no pre-place of t_{XOR} is marked with more than one token. No pre-place of t_{XOR} different from p is high-marked, because BPS is free of synchronization-deadlocks. Eventually, due to the lacking enabledness of (t_{XOR}, b) the transition t_{XOR} has at least one unmarked pre-place. In order to enable (t_{XOR}, b) at a reachable marking, it is necessary to create low-tokens at any of the unmarked pre-places of t_{XOR} . The skeleton $BPS^{skel} = (BPG^{skel}, \mu^{skel})$ is live. Therefore a minimal occurrence sequence $\mu^{skel} \xrightarrow{\sigma^{skel}} \mu_0^{skel}$ of BPS^{skel} exists with μ_0^{skel} enabling the transition $t^{skel} := skel(t_{XOR}) \in BPG^{skel}$. Due to Lemma 3.2 the occurrence sequence σ^{skel} lifts to an occurrence sequence $\mu \xrightarrow{\sigma_l} \mu_0$ of BPS with μ_0 enabling a binding element (t_{XOR}, b') , $b' \in B(t_{XOR})$. Because the minimal occurrence sequence σ^{skel} does not contain t^{skel} , the binding element (t_{XOR}, b) does not belong to σ_l . Therefore its pre-place p remains high-marked at μ_0 . Because BPS is free of synchronization-deadlocks, all other pre-places of t_{XOR} must be low-marked. We obtain $(t_{XOR}, b') = (t_{XOR}, b)$.

Claim: Every firing mode of σ_l is a low-mode, i.e. σ_l belongs to the low-system BPS^{low} . For the proof note that σ^{skel} fires exactly those transitions with an elementary path to t^{skel} which is token-free at μ^{skel} , and each of these transitions fires only once. Therefore σ_l contains only firing modes of transitions with a path to t_{XOR} which is token-free at μ . Moreover, all binding elements of σ_l belong to pairwise different transitions. Under the assumption that σ_l contains the high-mode of a transition, we select an elementary path $\gamma \subseteq supp(\sigma_l)$ from a high-marked pre-place of that transition to t_{XOR} . According to Lemma 3.2 we can choose the lift σ_l , so that its firing creates a high-token on a pre-place of t_{XOR} different from p . Therefore t_{XOR} is in a synchronization-deadlock at μ_0 . This contradiction proves that every binding element of σ_l is a low-mode. The concatenation $\sigma := \sigma_l \cdot \sigma_h$ is an enabled occurrence sequence of BPS^{flat} and lifts σ^{high} , because.

$$high(\sigma) = high(\sigma_l) \cdot high(\sigma_h) = high(\sigma_h) = \sigma^{high}. \quad \square$$

The BP-system from Fig. 5 is safe and high-live. Its high-system in Fig. 1 as well as its skeleton are safe and live, too. This correlation is a general truth according to the following theorem, which has been essentially demonstrated by Genrich and Thiagarajan ([GT1984], Theor. 3.13) and constitutes one of their main results.

3.5. Theorem (Safe and live BP-system)

For a safe and high-live BP-system the skeleton is safe and live and the high-system is safe and live without frozen tokens.

Proof:

i) Denote by $BPS = (BPG, \mu)$ the given BP-system. Safeness of BPS^{skel} follows from Lemma 3.2, and liveness of BPS^{skel} follows from Proposition 3.3. Safeness of BPS^{high} follows from Corollary 3.4. Because the high-system is a safe, strongly connected free-choice system, its deadlock-freeness is equivalent to liveness ([DE1995], Theor. 4.31). For an indirect proof of the deadlock-freeness we assume that $BPS^{high} = (BPG^{high}, \mu_1^{high})$ has a reachable dead marking μ_1^{high} . It is generated by an occurrence sequence $\mu^{high} \xrightarrow{\sigma^{high}} \mu_1^{high}$ which lifts to $\mu \xrightarrow{\sigma} \mu_1$ by Corollary 3.4. Because BPS is high-live by assumption, the marking μ_1 enables a high binding element (t, b) of at least one transition $t \in BPG$. Its image $high(t, b) \in BPG^{high}$ is a transition of the high-system enabled at μ_1^{high} , a contradiction.

ii) Exclusion of frozen tokens: For an indirect proof we assume the existence of a reachable marking μ_1^{high} and a place $high(p) \in BPG^{high}$ marked at μ_1^{high} with a frozen token. Denote by σ^{high} an enabled infinite occurrence sequence of $(BPG^{high}, \mu_1^{high})$ which does not move the frozen token. By Corollary 3.4 it lifts to an enabled infinite occurrence sequence σ of the BP-system (BPG, μ_1) which does not move the token at the place $p \in BPG$. Now $skel(\sigma)$ is an infinite enabled occurrence sequence of the skeleton BPS^{skel} with a frozen token at the place $skel(p) \in BPG^{skel}$. But the skeleton is a safe and live T -system as already proved in part i). Therefore it has no frozen tokens, cf. Lemma 1.6. This contradiction shows that also the high-system has no frozen tokens. \square

3.6. Corollary (Liveness with respect to all high bindings)

A safe and high-live BP-system is live with respect to all its high bindings.

Proof:

Denote by BPS the given BP-system. Its high-system and skeleton are safe and live by Theorem 3.5. By Proposition 3.3 the high-liveness of BPS implies that BPS is free of synchronization-deadlocks. By Corollary 3.4 every enabled occurrence sequence of BPS^{high} lifts to an enabled occurrence sequence of BPS . \square

The definition of *home states* translates literally from ordinary Petri nets to BP-systems. Here the existence of home states derives from the existence of blocking markings of the high-system. Corollary 3.7 proves a conjecture of Genrich and Thiagarajan ([GT1984], First conjecture in Chap. 4).

3.7. Corollary (Existence of home states)

Any safe and live BP-system has a home state.

Proof:

Let BPS be the given BP-system. According to Theorem 3.5 the high-system is safe and live and has no frozen tokens. Due to Lemma 1.13 any cluster c of the high-system has a unique blocking marking μ_{block}^{high} attached to it. It lifts to a reachable marking of BPS according to Corollary 3.4. After the subsequent

firing of a finite enabled occurrence sequence in the low-system we obtain a reachable marking μ of BPS with $high(\mu) = \mu_{block}^{high}$ and $skel(\mu)$ the blocking marking associated to the cluster $skel(c)$ in the skeleton. Evidently μ is uniquely determined in BPS by these two properties. The marking μ is a home state of BPS , because the blocking marking μ_{block}^{high} is a home state of the high-system and enabled occurrence sequences of the high-system lift to BPS . \square

4. Deriving liveness of BP-systems

In the present chapter we prove Theorem 4.6 as the main result of the paper. It entails the converse of Theorem 3.5. Because liveness of a BP-system follows from its deadlock-freeness, it suffices for the proof of Theorem 4.6 to focus on deadlock-freeness. Our proof will be indirect. Therefore we first study dead BP-systems.

Without loss of generality we concentrate on BP-systems with binary transitions. One can replace an arbitrary BP-system by a BP-system with only binary transitions without changing safeness and liveness. This substitution can be formalized by Petri net morphisms: One uses transition refinements which replace a given transition with an arbitrary number of pre- or post-places by a T -subnet with binary transitions. Because the fibers of the morphism are no longer discrete, one now has to consider the general definition of Petri net morphisms (cf. [Weh2006]). If not stated otherwise we assume that the BP-systems of the present chapter are binary.

The following Lemma 4.1 derives some simple properties of a dead marking of a BP-system. Note that the assumptions concerning the basic components in part ii) and iii) are satisfied if the high-system is safe.

4.1. Lemma (Dead BP-system)

Consider a dead BP-system BPS .

i) The pre-place of an opening transition is unmarked. In the high-system no closing transition is enabled.

ii) If the high-system is live and each of its marked places is contained in a basic component, then BPS contains at least one closing XOR-transition with one high-marked and one unmarked pre-place (cf. Fig. 16 on the left) and BPS contains no closing XOR-transition with two marked pre-places.

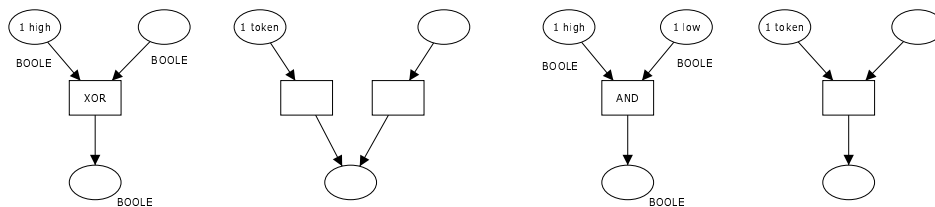

Figure 16. Closing transitions from a dead BP-system and corresponding high-system

iii) If the skeleton is safe and live and the high-system is live and each of its marked places is contained in a basic component, then the only transitions enabled in the skeleton have the form $skel(t_{AND})$

with a closing AND-transition t_{AND} in a synchronization-deadlock (cf. Fig. 16 on the right). Therefore BPS contains at least one closing AND-transition in a synchronization-deadlock.

Proof of Lemma 4.1.

Set $BPS = (BPG, \mu)$.

ad i) Any opening transition with a marked pre-place would be enabled, contradicting the deadness of BPS . Closing transitions of BPG^{high} correspond to closing AND-transitions of BPG . If the high-mode of the former were enabled, the latter would be enabled, too.

ad ii) If BPS^{high} is live, then at least one transition $high(t) \in BPS^{high}$, $t \in BPG$, is enabled. According to part i) the transition t is neither an opening transition nor a closing AND-transition. Therefore t is a closing XOR-transition with at least one high-marked pre-place. The other pre-place is unmarked: A high-token would contradict the assumption about the basic component. As Fig. 6 shows, in the high-system the resulting two tokens could not be separated by any P -component. A low-token would enable t , contradicting the deadness of BPS .

ad iii) If BPS^{skel} is safe and live, then at least one transition $skel(t) \in BPS^{skel}$ must be enabled. Due to part i) the corresponding transition $t \in BPG$ must be a closing transition with both pre-places marked and according to part ii) it cannot be an XOR-Transition. Therefore t is an AND-transition which is not enabled, but is in a synchronization-deadlock. Note that BPS is safe according to Lemma 3.1. \square

Our investigation of a dead BP-system is based on the two concepts of an XOR/AND-chain and of a deadlocking circle from Definition 4.2.

4.2. Definition (Deadlocking circle)

Consider a safe BP-system $BPS = (BPG, \mu)$.

i) An XOR/AND-chain of BPS leading from a closing XOR-transition t_{XOR} to a closing AND-transition t_{AND} is a tuple

$$Ch_{XOR/AND} = (t_{XOR}, t_{AND}, \alpha, N_B)$$

with a path α in BPG from t_{XOR} to t_{AND} and a basic component N_B of the high-system BPS^{high} , so that:

- One pre-place $p \in pre(t_{XOR})$ is high-marked at μ and the other pre-place from $pre(t_{XOR})$ is unmarked.
- The transition t_{AND} is in a synchronization-deadlock at μ , i.e. one pre-place $q \in pre(t_{AND})$ is high-marked and the other pre-place from $pre(t_{AND})$ is low-marked.
- The basic component N_B contains the marked place $q^{high} \in pre(t_{AND}^{high})$.
- The induced path $high(\alpha)$ of the high-net, which starts at the enabled high-mode t_{XOR}^{high} of t_{XOR} , satisfies

$$N_B \cap high(\alpha) = \{t_{AND}^{high}\}.$$

ii) If BPS is dead, then a deadlocking circle of size $m \geq 1$ of BPS is a family

$$(Ch_{i,XOR/AND}, \beta_i)_{i=0,\dots,m-1}$$

of XOR/AND-chains $Ch_{i,XOR/AND}$ leading from $t_{i,XOR}$ to $t_{i,AND}$, together with elementary token-free paths β_i in BPG , $i = 0, \dots, m - 1$, from $t_{i,AND}$ to $t_{i+1,XOR}$. A deadlocking circle is *minimal* if BPS has no deadlocking circle of smaller size.

One should note that any computation with indices from the index set $\{0, \dots, m - 1\}$ has to be understood *modulo* m .

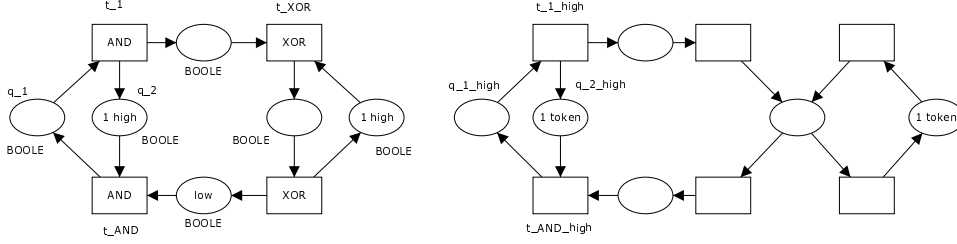

Figure 17. Deadlocking circle (left) and high-system (right)

Fig. 17, on the left, shows a dead BP-system with a deadlocking circle of size $m = 1$ which is formed by a single XOR/AND-chain

$$Ch_{XOR/AND} = (t_{XOR}, t_{AND}, \alpha, N_B)$$

together with a token-free path β . The transition t_{AND} is in a synchronization-deadlock. The path α is elementary. It starts at t_{XOR} and ends at t_{AND} . The elementary token-free path β starts at t_{AND} and ends at t_{XOR} . Fig. 17, on the right, shows the corresponding high-system with the subnet generated by the nodes $\{q_1^{high}, q_2^{high}, t_{AND}^{high}, t_1^{high}\}$ as the basic component N_B from $Ch_{XOR/AND}$.

4.3. Lemma (XOR/AND-chains and T-components)

Consider an XOR/AND-chain $Ch_{XOR/AND} = (t_{XOR}, t_{AND}, \alpha, N_B)$ of a safe BP-system and assume that the high-net is well-formed and structurally free of blocking. Then each T -component of the high net passing through the enabled high-mode t_{XOR}^{high} contains also the high-mode t_{AND}^{high} .

Proof:

We will give an indirect proof and assume the existence of a T -component N_T of the high-net which contains t_{XOR}^{high} but not t_{AND}^{high} . The basic component N_B contains the pre-place $q^{high} \in pre(t_{and}^{high})$. Therefore it cannot contain t_{XOR}^{high} and its marked pre-place $p^{high} \in N_T$. We have

$$t_{XOR}^{high} \in N_T - N_B, t_{AND}^{high} \in N_B - N_T \quad \text{and} \quad N_B \cap high(\alpha) = \{t_{AND}^{high}\},$$

so that Proposition 1.10 excludes the high-net being well-formed and structurally free of blocking. This contradiction proves the lemma. \square

The high-system from Fig. 17 (right) shows: It is necessary for the statement of Lemma 4.3 to assume, that the high-net is structurally free of blocking.

The following Lemma 4.4 states a sufficient condition that a dead BP-system has a deadlocking circle. The existence of deadlocking circles will be the starting point in the proof of Theorem 4.6, where we assume that the high-system is even safe. But Lemma 4.4 will be also applied in Chapter 5 under the weaker assumption about the basic components.

4.4. Lemma (Existence of deadlocking circles)

Consider a dead BP-system $BPS = (BPG, \mu)$ with a safe and live skeleton and a well-formed high-net. Assume that the high-system is live and that each of its marked places is contained in a basic component. Then

- i) BPS contains a closing AND-transition t_{AND} in a synchronization-deadlock.
- ii) Any closing AND-transition t_{AND} of BPS in a synchronization-deadlock extends to an XOR/AND-chain.
- iii) Some XOR/AND-chain of BPS extends to a deadlocking circle.

Proof:

i) According to Lemma 4.1, iii) BPS has a closing AND-transition t_{AND} in a synchronization-deadlock.

ii) Consider a closing AND-transition t_{AND} of BPS in a synchronization-deadlock. In the high-system we denote by $q_1^{high} \in pre(t_{AND}^{high})$ the marked pre-place and by $q_2^{high} \in pre(t_{AND}^{high})$ the unmarked pre-place. The place q_1^{high} is contained in a basic component N_B . Because the high-system is live, it has a minimal firing sequence σ^{high} , the firing of which activates t_{AND}^{high} by creating a token at q_2^{high} . Tracing the token flow due to the firing of σ^{high} back from q_2^{high} eventually identifies a path $\alpha \subset BPG$ with the following properties:

- α starts at a transition $t \in BPG$ with a high-mode t^{high} enabled at μ^{high} and ends at t_{AND}
- The firing of σ^{high} moves a token in the high-system along $high(\alpha)$ from a marked pre-place $p^{high} \in pre(t^{high})$ to q_2^{high} .

In the dead BP-system BPS the transition $t \in BPG$ must be a closing XOR-transition $t_{XOR} := t$, not enabled at μ . The place $p \in pre(t_{XOR})$ is high-marked. Because the marked place p^{high} is contained in a basic component, the other pre-place of t_{XOR} is unmarked at μ . The token at q_1^{high} is on hold during the firing of the minimal firing sequence σ^{high} . Because N_B is a basic component, we conclude $N_B \cap high(\alpha) = \{t_{AND}^{high}\}$. Therefore

$$Ch_{XOR/AND} := (t_{XOR}, t_{AND}, \alpha, N_B)$$

is an XOR/AND-chain.

iii) Due to part i) and ii) at least one XOR/AND-chain exists. We enumerate all XOR/AND-chains of BPS as $Ch_{i,XOR/AND}, i = 0, \dots, r-1$. Because the skeleton is live, each initial transition of an XOR/AND-chain can be reached from the final transition of the same or another XOR/AND-chain by an unmarked path. After possibly renumbering a subset of XOR/AND-chains we obtain a deadlocking circle. \square

The following Lemma 4.5 states the core of the proof for Theorem 4.6.

4.5. Lemma (Exclusion of deadlocking circles)

Consider a BP-system BPS with a safe and live skeleton. If BPS has a deadlocking circle, then the high-net cannot be well-formed and structurally free of blocking at the same time.

Before entering into the proof we will consider a particular case which serves to isolate the principal ideas. We assume that a deadlocking circle of size $m = 1$ exists, i.e. an XOR/AND-chain

$$Ch_{XOR/AND} = (t_{XOR}, t_{AND}, \alpha, N_B)$$

with a path α from a closing XOR-transition t_{XOR} to a closing AND-transition t_{AND} and a token-free path β from t_{AND} to t_{XOR} . Here t_{AND} is in a synchronization-deadlock and t_{XOR} has exactly one high-marked pre-place $p \in pre(t_{XOR})$, cf. Fig.18.

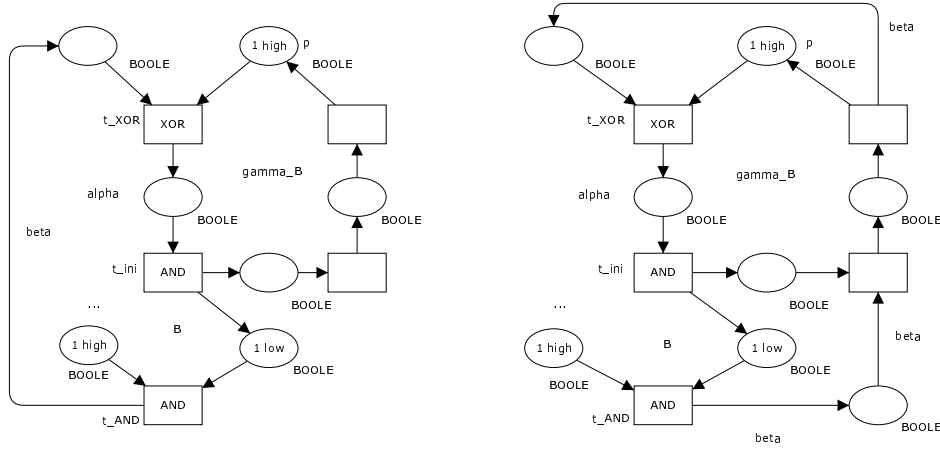

Figure 18. Two BP-systems with a deadlocking circle of size $m = 1$

Because the skeleton is safe and live, a basic circuit γ_B of $BPS = (BPG, \mu)$ exists passing through p but not through t_{AND} , because all pre-places of t_{AND} are marked. The basic circuit determines in the high-system an elementary circuit γ_B^{high} . It is contained in a T -component N_T , because the high-net is well-formed, cf. [TV1984], Chap. 5. The T -component N_T passes through $high(t_{AND})$ by Lemma 4.3. Therefore a bridge B^{high} exists within N_T from γ_B^{high} to $high(t_{AND})$. Places in N_T do not branch. Therefore the bridge starts with an opening transition, which is the high-mode of an opening AND-transition t_{ini} . Moreover $\gamma_B \cap B = \{t_{ini}\}$ for the corresponding path B in BPG . There are two possibilities for the token-free path β :

- Either β and γ_B have no nodes in common other than t_{XOR} , cf. the left part of Fig.18. Concatenating the paths B, β and the segment of γ_B from t_{XOR} to t_{ini} induces in the high-net a TP -handle on the elementary circuit γ_B^{high} , which contradicts the high-net being well-formed.
- Or β and γ_B intersect in a second node x different from t_{XOR} , cf. the right part of Fig.18. Then we obtain a token-free circuit of BPS by concatenating the segment of γ_B from t_{XOR} to x with the segment of β from x to t_{XOR} , which contradicts the skeleton being live.

Both possibilities are excluded which completes the proof for this special case.

In order to prove Lemma 4.5 in the general case, we have to consider deadlocking circles of arbitrary size which requires some additional index notation.

Proof of Lemma 4.5.

Because $BPS = (BPG, \mu)$ has a deadlocking circle, it also has a minimal deadlocking circle

$$(Ch_{i,XOR/AND}, \beta_i)_{i=0,\dots,m-1} \text{ of size } m \geq 1$$

with XOR/AND-chains $Ch_{i,XOR/AND} = (t_{i,XOR}, t_{i,AND}, \alpha_i, N_{i,B})$, cf. Fig.19.

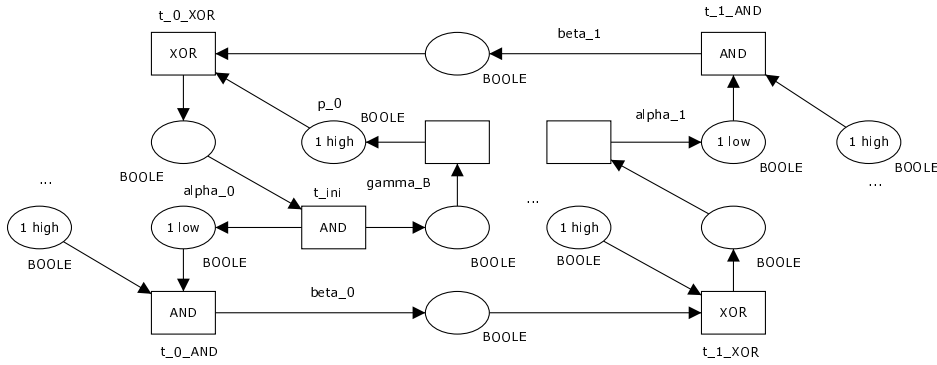

Figure 19. Deadlocking circle of size $m = 2$

We argue by means of an indirect proof and assume that the high-net $N := BPG^{high}$ is well-formed and structurally free of blocking.

i) Distinguishing a basic circuit: Because the skeleton BPS^{skel} is live and safe, a basic circuit γ_B of BPS passing through the high-marked pre-place $p_0 \in pre(t_{0,XOR})$ exists. It does not pass through any of the transitions in a synchronization-deadlock $t_{i,AND}$, $i = 0, \dots, m - 1$, because both of their pre-places are marked.

First claim: For every index $i = 0, \dots, m - 1$ holds

$$\gamma_B \cap \beta_i = \begin{cases} \emptyset & i \neq m - 1 \\ \{t_{0,XOR}\} & i = m - 1 \end{cases}$$

For the proof assume on the contrary the existence of a node $x \in \gamma_B \cap \beta_i$, $x \neq t_{0,XOR}$.

In case $i = m - 1$ we obtain an unmarked circuit by concatenating the segment of γ_B from $t_{0,XOR}$ to x with the segment of β_{m-1} from x to $t_{0,XOR}$. This contradicts the liveness of the skeleton. In case $i \neq m - 1$ we obtain an unmarked path from $t_{m-1,AND}$ to $t_{i+1,XOR}$ by concatenating three single paths: Firstly β_{m-1} , secondly the segment of γ_B from $t_{0,XOR}$ to x and as third the segment of β_i from x to $t_{i+1,XOR}$. Connecting $Ch_{m-1,XOR/AND}$ and $Ch_{i+1,XOR/AND}$ by the resulting path and skipping all XOR/AND-chains $Ch_k,XOR/AND$ with $0 \leq k \leq i$ produces a deadlocking circle of smaller size than the original minimal one. This contradiction proves the first claim.

The basic circuit γ_B determines in the high-system an elementary circuit $\gamma_B^{high} \subseteq BPG^{high}$. Because N is well-formed, there is a T -component N_T of N with $\gamma_B^{high} \subseteq N_T$ by [TV1984], Chap. 5. Let

$i \in \{0, \dots, m-1\}$ be the maximal index with $high(t_{i,AND}) \in N_T$. Such an index exists: Because the high-net is structurally free of blocking, at least for the index $i = 0$ holds $high(t_{0,AND}) \in N_T$ according to Lemma 4.3. Let $B^{high} \subseteq N_T$ be a bridge from γ_B^{high} to $high(t_{i,AND}) \in N_T - \gamma_B^{high}$. As a path within the T -component B^{high} starts with a transition. It is the high-mode of an AND-transition t_{ini} . We have $\gamma_B \cap B = \{t_{ini}\}$ with $B \subset BPG$ the corresponding path satisfying $high(B) = B^{high}$.

Second claim: For every index $j = i+1, \dots, m-1$ holds $\gamma_B \cap \alpha_j = \emptyset$. We argue by means of an indirect proof and assume the existence of an index $j \in \{i+1, \dots, m-1\}$ and a node $x \in \gamma_B \cap \alpha_j$. From

$$\gamma_B^{high} \subseteq N_T, high(t_{j,AND}) \notin N_T \quad \text{and} \quad N_{j,B} \cap high(\alpha_j) = \{high(t_{j,AND})\}$$

we conclude that

$$x_T := high(x) \in N_T - N_{j,B}, x_B := high(t_{j,AND}) \in N_{j,B} - N_T$$

and that the segment of $high(\alpha_j)$ from x_T to x_B is disjoint to $N_{j,B} \cap N_T$. According to Proposition 1.10 the high-net cannot be well-formed and structurally free of blocking. This contradiction proves the second claim.

ii) Derivation of a TP -handle on the basic circuit: With the help of the distinguished maximal index $i \in \{0, \dots, m-1\}$ from part i) with $high(t_{i,AND}) \in N_T$ we define the concatenated path

$$H := B * \beta_i * (\alpha_{i+1} * \beta_{i+1}) * \dots * (\alpha_{m-1} * \beta_{m-1}) \subset BPG$$

from t_{ini} to $t_{0,XOR}$. Due to part i) of the proof we have $\gamma_B \cap H = \{t_{ini}, t_{0,XOR}\}$. After possibly shortening H to an elementary path, keeping fixed its start and end, we obtain in the high-net a TP -handle H^{high} on the elementary circuit γ_B^{high} . By Theorem 1.7 this fact contradicts the well-formedness of the high-net and finishes the proof of the lemma. \square

Note. The underlying net of the BP-systems in the statement of Theorem 4.6 and Corollary 4.7 is not necessarily supposed as binary.

4.6. Theorem (Safeness and liveness of BP-systems)

A BP-system is safe and live with respect to all its high bindings if and only if its skeleton is safe and live and its high-system is safe and live without frozen tokens.

Proof:

i) The statement, which assumes a safe and live BP-system, is Theorem 3.5.

ii) To prove the reverse direction: The safeness of the skeleton implies the safeness of the BP-system according to Lemma 3.1. To prove its liveness with respect to all high bindings it suffices according to Corollary 3.6 to prove its high-liveness. For this purpose it suffices according to Proposition 3.3 to exclude that a reachable marking is dead. Assume on the contrary that the BP-system has a reachable dead marking. Then Lemma 4.4 combined with Lemma 4.5 provides a contradiction which proves the theorem. \square

The following Corollary 4.7 is due to Genrich and Thiagarajan ([GT1984], Theor. 4.10).

4.7. Corollary (Full reachability class)

A BP-system (BPG, μ_0) is safe and live with respect to all its high bindings iff (BPG, μ) is safe and live with respect to all its high bindings for every marking $\mu \in [\mu_0]$ from the full reachability class of μ_0 .

Proof:

Set $BPS := (BPG, \mu)$. Only one direction needs an explicit proof: We assume that μ_0 is reachable in BPS and that (BPG, μ_0) is safe and live with respect to all high bindings. We have to prove that also BPS is safe and live with respect to all high bindings: The morphisms

$$BPS \xrightarrow{skel} BPS^{skel} \quad \text{and} \quad BPS^{flat} \xrightarrow{high} BPS^{high}$$

imply that μ_0^{skel} is reachable in BPS^{skel} and μ_0^{high} is reachable in BPS^{high} . The P -coverability theorem for a well-formed free-choice net ([DE1995], Theor. 5.6) implies that every marking from the full reachability class of a safe and live marking is safe and live itself. Therefore BPS^{skel} as well as BPS^{high} are safe and live. By Theorem 3.5 and Lemma 1.6 the high-net BPG^{high} is structurally free of blocking. Now Theorem 4.6 implies that BPS is safe and live with respect to all its high bindings. \square

5. Live BP-systems with prescribed high-system or prescribed skeleton

In the present chapter we derive some implications of the main Theorem 4.6. In particular, we answer a question of Desel (Theorem 5.3) and prove a second conjecture of Genrich and Thiagarajan (Theorem 5.5).

The following two Lemmata 5.1 and 5.2 prepare the proof of Theorem 5.3. A safe and live BP-system has no reachable marking with high-tokens on each of the two post-places of a binary opening XOR-transition. Such a marking would contradict the safeness and liveness of the high-system, because the two induced tokens are not separable by a basic component. If one post-place of the opening XOR-transition is marked with a high-token, then the other post-place is either unmarked or marked with a low-token. Lemma 5.1 generalizes this statement.

5.1. Lemma (Firing an opening XOR-transition)

Consider a safe and high-live BP-system $BPS = (BPG, \mu)$ with a binary BP-graph BPG . Assume an opening XOR-transition t_{XOR} with one of its post-places high-marked at μ and the other unmarked. Then no elementary path from the unmarked post-place exists, which is marked at μ with a high-token and contains no other token.

Proof:

We denote by $p \in pre(t_{XOR})$ the pre-place of t_{XOR} , by $q \in post(t_{XOR})$ the post-place, which is high-marked at μ , and by $r \in post(t_{XOR})$ the other post-place, cf. Fig.20. For an indirect proof of the lemma we assume an elementary path α_μ from r to a place u_μ and assume that α_μ is marked at μ with a high-token on u_μ and contains no other token.

i) We claim that no transition from $post(q) \cup post(r)$ is a closing AND-transition: Otherwise a closing AND-transition $t_{AND} \in post(s) \subset BPG$ exists with a place $s \in \{q, r\}$, cf. Fig.20.

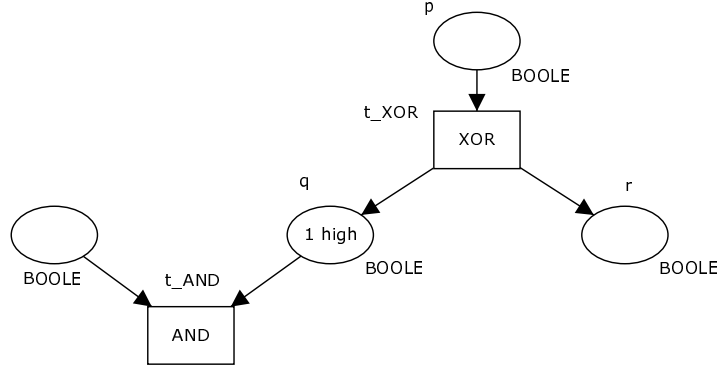

Figure 20. Closing AND-transition $t_{AND} \in post(s)$ in case $s = q$

In the high-net BPG^{high} we select a P -component N_P passing through t_{AND}^{high} but omitting s^{high} and p^{high} , and we select a T -component N_T passing through p^{high} but omitting s^{high} and t_{AND}^{high} . We apply Proposition 1.10 with

$$x_T := p^{high} \in N_T - N_P, \quad x_P := t_{AND}^{high} \in N_P - N_T$$

and α the elementary path from x_T to x_P . Because α is disjoint to $N_T \cap N_P$ the high-net cannot be well-formed and structurally free of blocking. This fact contradicts Theorem 3.5. and proves the claim.

ii) We consider the blocking marking μ_q^{high} associated to the cluster $cl(q^{high})$ in the high-system. According to Lemma 1.13 there exists a minimal occurrence sequence σ_q^{high} which fires according to

$$\mu^{high} \xrightarrow{\sigma_q^{high}} \mu_q^{high}.$$

According to Corollary 3.4 it lifts to BPS . By possibly firing the low-system the lift can be extended to an occurrence sequence σ_q of BPS firing according to

$$\mu \xrightarrow{\sigma_q} \mu_q,$$

so that $high(\mu_q) = \mu_q^{high}$ and $skel(\mu_q)$ is the blocking marking of $cl(skel(q))$ in the skeleton. Due to the safeness of the high-system no high-mode of t_{XOR} belongs to σ_q^{high} . And due to the safeness of the skeleton, $skel(t_{XOR})$ does not belong to $skel(\sigma_q)$. Because the skeleton BPG^{skel} is a T -net, the token content of the path α_μ can increase only by firing t_{XOR} and decrease only by firing a transition from $post(u_\mu)$. No firing mode of t_{XOR} belongs to σ_q , therefore the token content of α_μ cannot increase during firing σ_q . The flow of the high-token of α_μ due to the firing of σ_q extends α_μ to a path α_q from r to a place u_q , so that α_q is marked at μ_q with a high-token at u_q and contains no other token.

iii) Secondly, we consider the blocking marking μ_p^{high} associated to the cluster $cl(p^{high})$ in the high-system. We select a minimal occurrence sequence σ_p^{high} of the high-system firing according to

$$\mu_q^{high} \xrightarrow{\sigma_p^{high}} \mu_p^{high}.$$

Analogously to part ii) it lifts to an occurrence sequence σ_P of BPS firing according to

$$\mu_q \xrightarrow{\sigma_P} \mu_P \quad \text{with} \quad \text{high}(\mu_P) = \mu_P^{\text{high}}.$$

At μ_P we fire that high-mode of t_{XOR} which creates a marking μ_1 of BPS that high-marks q and low-marks r . At μ_1 the path α_q contains a low-token at r . Because $\text{post}(q)$ does not contain a closing AND-transition according to part i), the marking $\text{high}(\mu_1)$ of the high-system is the blocking marking μ_q^{high} of $\text{cl}(q^{\text{high}})$. After possibly firing the low-system at μ_1 we obtain a reachable marking μ_2 of BPS with $\text{high}(\mu_2) = \mu_q^{\text{high}}$ and $\text{skel}(\mu_2)$ the blocking marking of $\text{cl}(\text{skel}(q))$ in the skeleton. Because the skeleton BPG^{skel} is a T -net, we conclude that at μ_2 the path α_q is either token-free or contains at least one low-token.

iv) We apply Lemma 1.13: The uniqueness of blocking markings of the high-system and of the skeleton implies $\mu_q^{\text{high}} = \mu_2^{\text{high}}$ and $\text{skel}(\mu_q) = \text{skel}(\mu_2)$. Therefore $\mu_q = \mu_2$. On the other hand, the token content of α_q at μ_q is different from its token content at μ_2 . This contradiction completes the proof of the lemma. \square

5.2. Lemma (Retrograde lifting)

Consider a BP-system (BPG, μ) which is safe and live with respect to all its high bindings. Assume that BPG is binary. If a marking μ_0^{high} of the high-net enables an occurrence sequence

$$\mu_0^{\text{high}} \xrightarrow{\sigma^{\text{high}}} \text{high}(\mu),$$

then a marking μ_0 of BPG and an occurrence sequence $\mu_0 \xrightarrow{\sigma} \mu$ exist with

$$\text{high}(\mu_0) = \mu_0^{\text{high}} \quad \text{and} \quad \text{high}(\sigma) = \sigma^{\text{high}}.$$

Proof:

We denote by $N := BPG^{\text{high}}$ the high-net. Without loss of generality we may assume that σ^{high} is a single transition $\sigma^{\text{high}} = t^{\text{high}}$. There exists a well-determined binding element $(t, b) \in BPG$ with $\text{high}(t, b) = t^{\text{high}}$. For the token changes $\Delta\mu(\sigma^{\text{high}})$ due to the firing of σ^{high} and $\Delta\mu(\sigma)$ due to the firing of $\sigma := (t, b)$ in BPG holds

$$\text{high}(\Delta\mu(\sigma)) = \Delta\mu(\sigma^{\text{high}}).$$

i) If t is an opening AND-transition or an arbitrary closing transition, all its post-places from $\text{post}(t)$ are high-marked at μ and we have $\mu - \Delta\mu(\sigma) > 0$. Therefore

$$\mu_0 := \mu - \Delta\mu(\sigma)$$

is a marking of BPG and provides a lift with the necessary properties.

ii) If t is an opening XOR-transition $t = t_{XOR}$, we denote by p the pre-place of t_{XOR} and by q the post-place of t_{XOR} that is high-marked at μ . The other post-place r of t_{XOR} possibly lacks a low-token. Therefore not necessarily $\mu - \Delta\mu(\sigma) > 0$, this expression may fail to define a marking of BPG . If r lacks a low-token at μ , we have to fire the low-system in reverse direction until reaching a low-token

at r . This can be achieved by firing the skeleton in reverse direction from the marking $skel(\mu)$ and then making sure that it lifts to the reverse of the low-system BPS^{low} . The skeleton BPS^{skel} is a safe and live T -system. By reversing the orientation of its arcs - but keeping transitions, places and markings - we obtain the reverse skeleton which is a safe and live T -system, too. In the reverse skeleton we select a minimal occurrence sequence enabled at μ , the firing of which enables the transition $skel(t_{XOR})$. By Lemma 5.1 no elementary path exists in BPS which starts at r and contains at μ exactly one high-token and no other token. Therefore the occurrence sequence lifts to the reverse of BPS . \square

The next Theorem 5.3 answers in the positive a question of Desel².

5.3. Theorem (Live BP-system with prescribed high-system)

Any restricted free-choice system which is safe and live without frozen tokens is the high-system of a BP-system which is safe and live with respect to all its high bindings.

Proof:

We denote by $FCS = (N, \mu_0^{high})$ the given free-choice system. For the proof we may assume that all transitions of N are binary - also similar for places of N .

i) Catching all high-tokens within a T -component: We choose a T -component N_T of N . According to Proposition 1.11 a reachable marking μ_1^{high} of FCS exists which activates N_T . The component N_T contains all tokens of μ_1^{high} , because FCS has no frozen tokens.

ii) Adding low-tokens: The restricted free-choice net N extends to a unique binary BP-graph BPG with high-net $BPG^{high} = N$: The BP-graph BPG has a closing (opening) XOR-transition for the two pre-transitions (post-transitions) of a branched place of N and an AND-transition for every branched transition of N . We parametrize by

$$\Gamma := \{\gamma \subseteq BPG : \gamma \text{ elementary circuit and } \gamma^{high} \subseteq N_T\}$$

the set of all elementary circuits in N_T . Each of these circuits γ^{high} is marked at μ_1^{high} and a subset of basic circuits covers N_T . We now follow the iterative procedure in the proof of Genrichs Theorem ([DE1995], Theor. 3.20). Using the Petri net morphisms from Chapter 3 on the level of the underlying nets

$$BPG^{flat} \xrightarrow{high} BPG^{high}, \quad BPG \xrightarrow{skel} BPG^{skel}$$

we shall now produce a certain safe and live marking μ^{skel} of the skeleton BPG^{skel} without changing the marking of any elementary circuit $\gamma^{skel} := skel(\gamma), \gamma \in \Gamma$. These circuits cover

$$N_T^{skel} := skel(high^{-1}(N_T)),$$

the subnet of BPG^{skel} corresponding to $N_T \subseteq BPG^{high}$. To start the iteration we lift the marking μ_1^{high} from BPG^{high} to the well-defined marking $\mu_{1,h}$ of high-tokens on BPG with $high(\mu_{1,h}) = \mu_1^{high}$. We extend $skel(\mu_{1,h})$ to a live marking μ_1^{skel} of BPG^{skel} by adding a token to each place from $BPG^{skel} - N_T^{skel}$. The marking does not change the marking of any elementary circuit $\gamma^{skel}, \gamma \in \Gamma$.

²Personal communication 15.9.2006.

If the marking μ_1^{skel} is not safe already, a reachable marking of $(BPG^{skel}, \mu_1^{skel})$ exists which marks a certain place of BPG^{skel} with two or more tokens. This place must belong to $BPG^{skel} - N_T^{skel}$, because N_T^{skel} is covered by basic circuits. After removing all but one token from the place in question the resulting marking is still live, but the token content has decreased for at least one circuit not contained in N_T^{skel} . We iterate this step until the resulting live marking μ^{skel} of BPG^{skel} is also safe.

iii) Extending a certain reachable marking of FCS to BPG : We lift the restriction $\mu^{skel}|_{N_T^{skel}}$ to the well-defined marking μ_h of high-tokens on BPG with $skel(\mu_h) = \mu^{skel}|_{N_T^{skel}}$. There exists a well-defined marking μ^{high} on N_T with $high(\mu_h) = \mu^{high}$. The two markings $\mu_1^{high}|_{N_T}$ and μ^{high} agree on all P -flows of N_T , because they have the same token content on all elementary circuits $\gamma \in \Gamma$. Therefore the marking μ^{high} is a reachable marking of $(N_T, \mu_1^{high}|_{N_T})$ according to the Reachability Theorem for live T -systems ([DE1995], Theor. 3.21). Because N_T is a T -component of N , the marking μ^{high} is reachable in (N, μ_1^{high}) as well as in the original system FSC . Likewise we lift the restriction $\mu^{skel}|_{BPG^{skel} - N_T^{skel}}$ to the well-defined marking μ_l of low-tokens on BPG with $skel(\mu_l) = \mu^{skel}|_{BPG^{skel} - N_T^{skel}}$. The combined marking

$$\mu := \mu_h + \mu_l$$

defines the BP-system (BPG, μ) . Its high-system (N, μ^{high}) is safe and live without frozen tokens, and its skeleton (BPG^{skel}, μ^{skel}) is safe and live. Therefore (BPG, μ) is safe and live with respect to all its high bindings according to Theorem 4.6.

To complete the proof of the theorem we apply Lemma 5.2. It implies the existence of a marking μ_0 of BPG , so that FCS is the high-system of the BP-system $BPS := (BPG, \mu_0)$ which is safe and live with respect to all high bindings according to Corollary 4.7. \square

The following Theorem 5.5 answers affirmatively a further conjecture of Genrich and Thiagarajan ([GT1984], Second conjecture in Chap. 4). The theorem proves for a BP-graph with a high-net which is well-formed and structurally free of blocking: Any safe and live marking of the skeleton extends to a safe and high-live marking of the BP-graph. Theorem 5.5 is a companion to Theorem 5.3, where the marking of the high-net was prescribed and one had to add low-tokens. For proving Theorem 5.5 we will do the converse: We shall partition the tokens of the skeleton into high- and low-tokens, so that the high-tokens provide a safe and live marking of the high-net. First, we easily find a live marking of the high-net. Then, step by step, the simple Lemma 5.4 converts certain high-tokens to low-tokens, so that the resulting marking of the high-net stays live but eventually becomes safe. This iteration is a refined version of the algorithm in the standard proof of Genrich's theorem (cf. [DE1995], Theor. 5.10).

5.4. Lemma (Removing tokens from live free-choice systems)

Consider a live marking μ of a well-formed free-choice net N . For any place p of N which is marked at μ holds the equivalence:

- Removing a token from p results in a marking which is live, too.
- No basic component of (N, μ) passes through p .

Proof:

A marking of a well-formed free-choice net is live if and only if it marks every P -component. We denote by $\bar{\mu}$ the marking which results from μ by removing a token at p .

i) \Rightarrow ii) If $\bar{\mu}$ is live, then every P -component N_P containing p is marked at $\bar{\mu}$. Therefore N_P is marked at μ with at least two tokens.

ii) \Rightarrow i) Consider an arbitrary P -component N_P . If N_P does not contain p , then μ and $\bar{\mu}$ mark N_P alike. In particular, N_P is marked at $\bar{\mu}$. If N_P contains p , then μ marks N_P with at least two tokens, because p is not contained in any basic component of μ . Therefore $\bar{\mu}$ marks N_P with at least one token. \square

Note. Consider a bounded and live free-choice system. Even if each marked place is contained in a basic component, the free-choice system is not necessarily safe.

5.5. Theorem (Live BP-system with prescribed skeleton)

Consider a BP -graph BPG and assume that its high-net is well-formed and structurally free of blocking. Then any safe and live marking μ^{skel} of the skeleton BPG^{skel} is the skeleton of a marking μ of BPG which is safe and live with respect to all its high bindings:

$$(BPG^{skel}, \mu^{skel}) = (BPG, \mu)^{skel}.$$

Proof:

We denote by $N := BPG^{high}$ the high-net of BPG .

i) We consider the marking μ_0 of BPG which marks each place of $p \in BPG$ with a high-token if the corresponding place $skel(p) \in BPG^{skel}$ from the skeleton is marked at μ^{skel} :

$$\mu_0(p) := \begin{cases} high & p^{skel} \text{ marked at } \mu^{skel} \\ no \text{ token} & otherwise \end{cases}$$

By definition we have $(BPG, \mu_0)^{skel} = (BPG^{skel}, \mu^{skel})$. The induced marking μ_0^{skel} of the high-net is live, because it marks each P -component N_P with at least one token: Due to being a P -component N_P contains at least one circuit. The induced circuit in the skeleton is marked, because μ^{skel} is live.

ii) By induction we construct a finite sequence of markings $(\mu_i)_{i=0, \dots, n}$ of BPG with

- μ_i^{skel} is a reachable marking of (BPG^{skel}, μ^{skel})
- (N, μ_i^{high}) is live and
- For $i \geq 1$ the token count from all P -components N_P of the high-net $\sum_{N_P} \mu_i^{high}(N_P)$ is strictly decreasing with respect to i .

For the induction step assume that μ_i has already been constructed. Because μ_i^{skel} is a reachable marking of (BPG^{skel}, μ^{skel}) , the system $(BPG^{skel}, \mu_i^{skel})$ is safe, too, and Lemma 3.1 implies the safeness of (BPG, μ_i) . If the high-system (N, μ_i^{high}) is not safe, then an enabled occurrence sequence σ^{high} of (N, μ_i^{high}) exists, the firing of which creates a marking with at least two tokens at

a certain place of N . Because (BPG, μ_i) is safe, the occurrence sequence σ^{high} has no lift against $(BPG, \mu_i) \xrightarrow{high} (N, \mu_i^{high})$. Therefore (BPG, μ_i) has a reachable dead marking $\mu_{i,dead}$ according to Corollary 3.4. Because $\mu_{i,dead}^{high}$ is a reachable marking of (N, μ_i^{high}) the two markings $\mu_{i,dead}^{high}$ and μ_i^{high} induce the same token count on any P -component of N . We distinguish two cases.

Case 1: A high-token at $\mu_{i,dead}$ marks a place $p \in BPG$ with $p^{high} \in N$ not contained in any basic component of (N, μ_i^{high}) . We define μ_{i+1} as the marking of BPG which results from $\mu_{i,dead}$ by converting the high-token at p into a low-token. Then (N, μ_{i+1}^{high}) is live according to Lemma 5.4 and its token count from all P -components has decreased in comparison to (N, μ_i^{high}) . For the skeleton we have $\mu_{i+1}^{skel} = \mu_{i,dead}^{skel}$. Therefore μ_{i+1}^{skel} is a reachable marking of $(BPG^{skel}, \mu_i^{skel})$ and a posteriori of (BPG^{skel}, μ^{skel}) , which finishes the induction step.

Case 2: Each high-token of $\mu_{i,dead}$ marks a place $p \in BPG$ with $p^{high} \in N$ contained in a basic component of (N, μ_i^{high}) . According to Lemma 4.4 a deadlocking circle of (N, μ_i^{high}) exists, which contradicts Lemma 4.5 and excludes the second case.

Evidently, the iteration stops and holds a marking μ_n of BPG so that (N, μ_n^{high}) is safe and live and μ_n^{skel} is a reachable marking of (BPG^{skel}, μ^{skel}) .

iii) Theorem 4.6 implies that (BPG, μ_n) is safe and live with respect to all high bindings. Because the skeleton is cyclic an enabled occurrence sequence σ^{skel} of $(BPG^{skel}, \mu_n^{skel})$ exists, the firing of which creates the initial marking μ^{skel} . Due to Lemma 3.2 the occurrence sequence σ^{skel} lifts against $(BPG, \mu_n) \xrightarrow{skel} (BPG^{skel}, \mu_n^{skel})$ to an enabled occurrence sequence of (BPG, μ_n) . Its firing creates a marking μ of BPG which is safe and live with respect to all high bindings of BPG and satisfies $(BPG^{skel}, \mu^{skel}) = (BPG, \mu)^{skel}$. \square

In general, the first step in the proof of Theorem 5.5 creates too many high-tokens and the second step converts the redundant ones into low-tokens. It suffices to start with a T -component N_T and to high-mark only those places from $high^{-1}(N_T) \subseteq BPG$ which are marked in the skeleton. One obtains a live marking of N_T , which is live also as a marking of the high-net due to Corollary 1.9. But some high-tokens of $high^{-1}(N_T)$ possibly have to be converted to low-tokens. This is exemplified in Fig. 21:

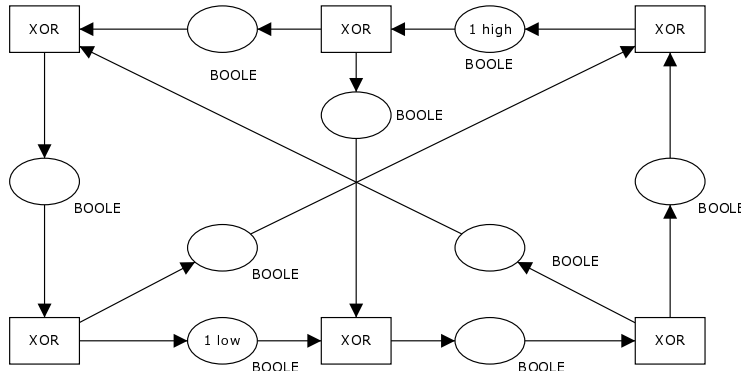

Figure 21. High-live BP-system with enabled T-component and a low-token

The outer circuit, which generates in the high-system an enabled T -component, is marked with a low-token, too.

5.6. Corollary (Well-formedness of BP-graphs)

A BP-graph is well-formed iff its high-net is well-formed and structurally free of blocking.

Proof:

Denote by BPG the given BP-graph.

i) If BPG is well-formed then a marking μ exists, such that the BP-system $BPS = (BPG, \mu)$ is safe and high-live. Due to Theorem 3.5 the high-system BPS^{high} is safe and live without frozen tokens. Hence BPG^{high} is well-formed and structurally free of blocking according to Lemma 1.6.

ii) Assume BPG^{high} being well-formed and structurally free of blocking. We choose a safe and live marking of the skeleton. Due to Theorem 5.5 it extends to a safe and high-live marking of BPG . \square

Note. In part ii) of the proof for Corollary 5.6 one could also apply first Genrichs Theorem for live and bounded free-choice systems and then use Theorem 5.3 instead of Theorem 5.5.

6. Perspectives

According to Theorem 4.6 BP-systems and restricted free-choice systems without frozen tokens are equivalent models for the control flow of well-behaved processes. One could therefore doubt if further studies of BP-systems are of any value. BP-systems are coloured Petri nets. Therefore they are more complex than free-choice systems. They introduce a second token colour to explicitly demonstrate the omission of actions. But as Theorem 4.6 shows, low-tokens are dispensable when well-behavedness occurs.

Our argument in favour of BP-systems goes into the opposite direction: Due to the importance of BP-systems for the semantics and analysis of EPCs it is helpful to generalize their type of logical transitions and to take more general Boolean systems into consideration. A characterization of safe and high-live Boolean systems with AND, XOR and OR-connectors is desirable. Fig. 2 shows the ordinary net generated by the high-places and high-transitions of a closing OR-transition. Neither the net is free-choice nor it is capable of representing the Boolean logic of the closing OR-connector of an EPC.

The present paper exemplified how to study Petri nets using morphisms. The morphisms in the context of the ordinary Petri net BPS^{flat} from Chapter 3 have their analogue within the context of coloured Petri nets. The coloured Petri net BPS is an extension

$$PN_0 \xrightarrow{low} BPS \xrightarrow{high} PN_1$$

of a coloured Petri net PN_1 by another coloured Petri net PN_0 . The Petri net PN_1 is isomorphic to a free-choice system, while PN_0 is isomorphic to a T -system. In [Weh2006] we have started the study of topological and algebraic aspects of morphisms between arbitrary coloured Petri nets.

References

- [BD1990] Best, Eike; Desel, Jörg: Partial Order Behaviour and Structure of Petri Nets. *Formal Aspects of Computing* (1990), p. 123-138
- [Des1986] Desel, Jörg: A structural property of Free-choice Systems. *Petri Net Newsletter* 25, 1986
- [DE1995] Desel, Jörg, Esparza, Javier: *Free Choice Petri Nets*. Cambridge University Press, Cambridge 1995
- [ES1990] Esparza, Javier; Silva, Manuel: Circuits, Handles, Bridges and Nets. In: Rozenberg, Grzegorz (Ed.) *Advances in Petri nets 1990*. Lecture Notes in Computer Science, vol. 483, Springer, Berlin 1990, p. 210-242
- [GHM2003] Gaujal, Bruno; Haar, Stefan; Mairesse, Jean: Blocking a transition in a Free Choice net and what it tells about its throughput. *Journal of Computer and System Sciences* 66 (2003), p. 515-548
- [GL2005] Gruhn, Volker; Laue, Ralf: Einfache EPK-Semantik durch praxistaugliche Stilregeln. In: Nüttgens, Markus; Rump, Frank (Hrsg.): *EPK 2005. Geschäftsprozessmanagement mit Ereignisgesteuerten Prozessketten*. Proceedings, Hamburg 2005
- [GT1984] Genrich, H.J.; Thiagarajan, P.S.: A Theory of Bipolar Synchronization Schemes. *Theoretical Computer Science* 30 (1984), p. 241-318
- [Jen1992] Jensen, Kurt: *Coloured Petri nets. Basic concepts, analysis methods and practical use*. Vol. 1. Springer, Berlin et al. 1992
- [LSW1998] Langner, Peter; Schneider, Christoph; Wehler, Joachim: Petri Net based Certification of Event-driven Process Chains. In: Desel, Jörg; Silva, Manuel (Eds.): *Application and Theory of Petri Nets 1998*. Lecture notes in Computer science, vol. 1420. Springer, Berlin et al. 1998
- [MA2006] Mendling, Jan; van der Aalst, Wil: Towards EPC Semantics based on State and Context. In: Nüttgens, Markus; Rump, Frank: *EPK 2006. Geschäftsprozessmanagement mit Ereignisgesteuerten Prozessketten*. 5. Workshop der Gesellschaft für Informatik, Wien, 2006
- [Sch1994] Scheer, August-Wilhelm: *Business Process Engineering. Reference Models for Industrial Enterprises*. Springer, Berlin et al. 1994
- [TV1984] Thiagarajan, P.S.; Voss, Klaus: A Fresh Look at Free Choice Nets. *Information and Control* 62 (1984), p. 85-113
- [Weh2006] Wehler, Joachim: *Morphisms of Coloured Petri Nets*, arXiv, cs.SE/0608038, 2006
- [Weh2007] Wehler, Joachim: Boolean and free-choice semantics of Event-driven Process Chains. EPK 2007. In: Nüttgens, Markus; Rump, Frank, Gadatsch, Andreas (Eds.): *6. GI-Workshop EPK 2007: Geschäftsprozessmanagement mit Ereignisgesteuerten Prozessketten*. St.Augustin, 2007.